

SUMMARY OF PRODUCT CHARACTERISTICS

1 NAME OF THE MEDICINAL PRODUCT

Omeprazole 4 mg/ml, Powder for Oral Suspension

2 QUALITATIVE AND QUANTITATIVE COMPOSITION

4 mg/ml: After constitution, each ml of suspension contains 4mg of omeprazole. Each constituted bottle (90ml) contains 360mg of omeprazole.

Excipients with known effect:

Each ml of suspension contains sodium methyl parahydroxybenzoate (E219) 2.3mg, maltitol (E965) 272mg, sodium benzoate (E211) 5mg, sodium 17.2mg and potassium 54.3 mg.

For the full list of excipients, see section 6.1.

3 PHARMACEUTICAL FORM

Powder for Oral Suspension

Powder in Cap: White / off-white / slightly yellow powder.

Powder in Bottle: White / off-white / slightly yellow powder. May contain dark specks due to sweetener.

4 CLINICAL PARTICULARS

4.1 Therapeutic indications

Omeprazole Oral Suspension is indicated for:

Adults

- Treatment of duodenal ulcers
- Prevention of relapse of duodenal ulcers
- Treatment of gastric ulcers
- Prevention of relapse of gastric ulcers
- In combination with appropriate antibiotics, *Helicobacter pylori* (*H. pylori*) eradication in peptic ulcer disease
- Treatment of NSAID-associated gastric and duodenal ulcers
- Prevention of NSAID-associated gastric and duodenal ulcers in patients at risk
- Treatment of reflux esophagitis
- Long-term management of patients with healed reflux esophagitis
- Treatment of symptomatic gastro-esophageal reflux disease

Paediatric use

Children over 1 month of age

- Treatment of reflux esophagitis
- Symptomatic treatment of heartburn and acid regurgitation in gastro-esophageal reflux disease

Children over 4 years of age and adolescents

In combination with antibiotics in treatment of duodenal ulcer caused by *H. pylori*

4.2 Posology and method of administration

Omeprazole 2mg/ml Oral Suspension is suitable for doses of ≤ 15 mg. For doses of 20mg or greater, Omeprazole 4mg/ml Oral Suspension is suitable.

Posology in adults

Treatment of duodenal ulcers

The recommended dose in patients with an active duodenal ulcer is Omeprazole 20 mg once daily. In most patients healing occurs within two weeks. For those patients who may not be fully healed after the initial course, healing usually occurs during a further two weeks treatment period. In patients with poorly responsive duodenal ulcer Omeprazole 40 mg once daily is recommended and healing is usually achieved within four weeks.

Prevention of relapse of duodenal ulcers

For the prevention of relapse of duodenal ulcer in *H. pylori* negative patients or when *H. pylori* eradication is not possible the recommended dose is Omeprazole 20 mg once daily. In some patients a daily dose of 10 mg may be sufficient. In case of therapy failure, the dose can be increased to 40 mg.

Treatment of gastric ulcers

The recommended dose is Omeprazole 20 mg once daily. In most patients healing occurs within four weeks. For those patients who may not be fully healed after the initial course, healing usually occurs during a further four weeks treatment period. In patients with poorly responsive gastric ulcer Omeprazole 40 mg once daily is recommended and healing is usually achieved within eight weeks.

Prevention of relapse of gastric ulcers

For the prevention of relapse in patients with poorly responsive gastric ulcer the recommended dose is Omeprazole 20 mg once daily. If needed the dose can be increased to Omeprazole 40 mg once daily.

H. pylori eradication in peptic ulcer disease

For the eradication of *H. pylori* the selection of antibiotics should consider the individual patient's drug tolerance, and should be undertaken in accordance with national, regional and local resistance patterns and treatment guidelines.

- Omeprazole 20 mg + clarithromycin 500 mg + amoxicillin 1,000 mg, each twice daily for one week, or
- Omeprazole 20 mg + clarithromycin 250 mg (alternatively 500 mg) + metronidazole 400 mg (or 500 mg or tinidazole 500 mg), each twice daily for one week or
- Omeprazole 40 mg once daily with amoxicillin 500 mg and metronidazole 400 mg (or 500 mg or tinidazole 500 mg), both three times a day for one week.

In each regimen, if the patient is still *H. pylori* positive, therapy may be repeated.

Treatment of NSAID-associated gastric and duodenal ulcers

For the treatment of NSAID-associated gastric and duodenal ulcers, the recommended dose is Omeprazole 20 mg once daily. In most patients healing occurs within four weeks. For those patients who may not be fully healed after the initial course, healing usually occurs during a further four weeks treatment period.

Prevention of NSAID-associated gastric and duodenal ulcers in patients at risk

For the prevention of NSAID-associated gastric ulcers or duodenal ulcers in patients at risk (age > 60, previous history of gastric and duodenal ulcers, previous history of upper GI bleeding) the recommended dose is Omeprazole 20 mg once daily.

Treatment of reflux esophagitis

The recommended dose is Omeprazole 20 mg once daily. In most patients healing occurs within four weeks. For those patients who may not be fully healed after the initial course, healing usually occurs during a further four weeks treatment period.

In patients with severe esophagitis Omeprazole 40 mg once daily is recommended and healing is usually achieved within eight weeks.

Long-term management of patients with healed reflux esophagitis

For the long-term management of patients with healed reflux esophagitis the recommended dose is Omeprazole 10 mg once daily. If needed, the dose can be increased to Omeprazole 20-40 mg once daily.

Treatment of symptomatic gastro-esophageal reflux disease

The recommended dose is Omeprazole 20 mg daily. Patients may respond adequately to 10 mg daily, and therefore individual dose adjustment should be considered.

If symptom control has not been achieved after four weeks treatment with Omeprazole 20 mg daily, further investigation is recommended.

Paediatric population

Children over 1 month of age

Treatment of reflux esophagitis

Symptomatic treatment of heartburn and acid regurgitation in gastro-esophageal reflux disease

The posology recommendations are as follows*:

Age	Weight	Posology
1 month to 1 year of age	-	1 mg/kg once daily. Doses above 1.5 mg/kg/day have not been studied.
≥ 1 year of age	10-20 kg	10 mg once daily. The dose can be increased to 20 mg once daily if needed.
≥ 2 years of age	> 20 kg	20 mg once daily. The dose can be increased to 40 mg once daily if needed.

* The 2 mg/ml and 4 mg/ml strengths are equivalent with respect to buffering capacity (same amount of buffer on a ml basis). For doses of ≤ 15mg, the 2 mg/ml strength is recommended. The 2 mg/ml strength is indicated for age 1 month to 1 year for administering up to 15mg and ≥ 1 year of age for administering 10mg, to provide sufficient buffering capacity and absorption. For doses of 20mg or 40mg, the 4mg/ml strength is suitable. The 4 mg/ml strength is indicated for administration of 20mg or 40mg so that a maximum of 2 doses are required.

Reflux esophagitis: The treatment time is 4-8 weeks.

Symptomatic treatment of heartburn and acid regurgitation in gastro-esophageal reflux disease: The treatment time is 2-4 weeks. If symptom control has not been achieved after 2-4 weeks the patient should be investigated further.

Children over 4 years of age and adolescents

Treatment of duodenal ulcer caused by H. pylori

When selecting appropriate combination therapy, consideration should be given to official national, regional and local guidance regarding bacterial resistance, duration of treatment (most commonly 7 days but sometimes up to 14 days), and appropriate use of antibacterial agents.

The treatment should be supervised by a specialist.

The posology recommendations are as follows:

Weight	Posology
15-30 kg	Combination with two antibiotics: Omeprazole 10 mg, amoxicillin 25 mg/kg body weight and clarithromycin 7.5 mg/kg body weight are all administrated together two times daily for one week.
31-40 kg	Combination with two antibiotics: Omeprazole 20 mg, amoxicillin 750 mg and clarithromycin 7.5 mg/kg body weight are all administrated two times daily for one week.
> 40 kg	Combination with two antibiotics: Omeprazole 20 mg, amoxicillin 1 g and clarithromycin 500 mg are all administrated two times daily for one week.

Special populations

Renal impairment

Dose adjustment is not needed in patients with impaired renal function (see section 5.2).

Hepatic impairment

In patients with impaired hepatic function a daily dose of 10–20 mg may be sufficient (see section 5.2).

Elderly (> 65 years old)

Dose adjustment is not needed in the elderly (see section 5.2).

Method of administration

Omeprazole Oral Suspension should be taken on an empty stomach, at least 30 minutes before a meal.

Precautions to be taken before handling or administering the medicinal product

Omeprazole powder for oral suspension requires reconstitution prior to oral administration. For instructions on reconstitution of the medicinal product before administration, see section 6.6.

For instruction for administration via nasogastric (NG) or percutaneous endoscopic gastrostomy (PEG) tubes, see section 6.6

4.3 Contraindications

Hypersensitivity to the active substance, substituted benzimidazoles or to any of the excipients listed in section 6.1.

Omeprazole like other proton pump inhibitors (PPIs) must not be used concomitantly with nelfinavir (see section 4.5).

4.4 Special warnings and precautions for use

In the presence of any alarm symptom (e.g. significant unintentional weight loss, recurrent vomiting, dysphagia, haematemesis or melena) and when gastric ulcer is suspected or present, malignancy should be excluded, as treatment may alleviate symptoms and delay diagnosis.

Co-administration of atazanavir with proton pump inhibitors is not recommended (see section 4.5). If the combination of atazanavir with a proton pump inhibitor is judged unavoidable, close clinical monitoring (e.g. virus load) is recommended in combination with an increase in the dose of atazanavir to 400 mg with 100 mg of ritonavir; omeprazole 20 mg should not be exceeded.

Omeprazole, as all acid-blocking medicines, may reduce the absorption of vitamin B₁₂ (cyanocobalamin) due to hypo- or achlorhydria. This should be considered in patients with reduced body stores or risk factors for reduced vitamin B₁₂ absorption on long-term therapy.

Omeprazole is a CYP2C19 inhibitor. When starting or ending treatment with omeprazole, the potential for interactions with drugs metabolised through CYP2C19 should be considered. An interaction is observed between clopidogrel and omeprazole (see section 4.5). The clinical relevance of this interaction is uncertain. As a precaution, concomitant use of omeprazole and clopidogrel should be discouraged.

Severe hypomagnesaemia has been reported in patients treated with proton pump inhibitors (PPIs) like omeprazole for at least three months, and in most cases for a year. Serious manifestations of hypomagnesaemia such as fatigue, tetany, delirium, convulsions, dizziness and ventricular arrhythmia can occur but they may begin insidiously and be overlooked. In most affected patients, hypomagnesaemia improved after magnesium replacement and discontinuation of the PPI.

For patients expected to be on prolonged treatment or who take PPIs with digoxin or drugs that may cause hypomagnesaemia (e.g. diuretics), healthcare professionals should consider measuring magnesium levels before starting PPI treatment and periodically during treatment.

Proton pump inhibitors, especially if used in high doses and over long durations (>1 year), may modestly increase the risk of hip, wrist and spine fracture, predominantly in the elderly or in presence of other recognised risk factors. Observational studies suggest that proton pump inhibitors may increase the overall risk of fracture by 10-40%. Some of this increase may be due to other risk factors. Patients at risk of

osteoporosis should receive care according to current clinical guidelines and they should have an adequate intake of vitamin D and calcium.

Severe cutaneous adverse reactions (SCARs) including Stevens-Johnson syndrome (SJS), toxic epidermal necrolysis (TEN), drug reaction with eosinophilia and systemic symptoms (DRESS) and acute generalized exanthematous pustulosis (AGEP), which can be life-threatening or fatal, have been reported very rarely and rarely, respectively in association with omeprazole treatment.

Renal impairment

Acute tubulointerstitial nephritis (TIN) has been observed in patients taking omeprazole and may occur at any point during omeprazole therapy (see section 4.8). Acute tubulointerstitial nephritis can progress to renal failure.

Omeprazole should be discontinued in case of suspected TIN, and appropriate treatment should be promptly initiated.

Subacute cutaneous lupus erythematosus (SCLE)

Proton pump inhibitors are associated with very infrequent cases of SCLE. If lesions occur, especially in sun-exposed areas of the skin, and if accompanied by arthralgia, the patient should seek medical help promptly and the health care professional should consider stopping Omeprazole. SCLE after previous treatment with a proton pump inhibitor may increase the risk of SCLE with other proton pump inhibitors.

Interference with laboratory tests

Increased Chromogranin A (CgA) level may interfere with investigations for neuroendocrine tumours. To avoid this interference, omeprazole treatment should be stopped for at least 5 days before CgA measurements (see section 5.1). If CgA and gastrin levels have not returned to reference range after initial measurement, measurements should be repeated 14 days after cessation of proton pump inhibitor treatment.

Some children with chronic illnesses may require long-term treatment although it is not recommended.

Treatment with proton pump inhibitors may lead to slightly increased risk of gastrointestinal infections such as *Salmonella* and *Campylobacter* and, in hospitalised patients, possibly also *Clostridium difficile* (see section 5.1).

As in all long-term treatments, especially when exceeding a treatment period of 1 year, patients should be kept under regular surveillance.

This medicinal product contains 17.2mg (0.75mmol) of sodium per ml or 86mg (3.75mmol) of sodium per 5ml dose, equivalent (for 5ml dose) to 4.3% of the WHO recommended maximum daily intake of 2 g sodium for an adult.

This medicine contains 54.3mg (1.39 mmol) potassium per ml or 271.5mg

(6.95mmol) of potassium per 5ml dose. To be taken into consideration by patients with reduced kidney function or patients on a controlled potassium diet.

This medicinal product contains sodium methyl para hydroxybenzoate, which may cause allergic reactions (possibly delayed).

This medicine contains 5 mg sodium benzoate in each 1ml.

This product contains maltitol. Patients with rare hereditary problems of fructose intolerance should not take this medicine.

4.5 Interaction with other medicinal products and other forms of interaction

Effects of omeprazole on the pharmacokinetics of other active substances

Active substances with pH dependent absorption

The decreased intragastric acidity during treatment with omeprazole might increase or decrease the absorption of active substances with a gastric pH dependent absorption.

Nelfinavir, atazanavir

The plasma levels of nelfinavir and atazanavir are decreased in case of co-administration with omeprazole.

Concomitant administration of omeprazole with nelfinavir is contraindicated (see section 4.3). Co-administration of omeprazole (40 mg once daily) reduced mean nelfinavir exposure by ca. 40% and the mean exposure of the pharmacologically active metabolite M8 was reduced by ca. 75 –90%. The interaction may also involve CYP2C19 inhibition.

Concomitant administration of omeprazole with atazanavir is not recommended (see section 4.4). Concomitant administration of omeprazole (40 mg once daily) and atazanavir 300 mg/ritonavir 100 mg to healthy volunteers resulted in a 75% decrease of the atazanavir exposure. Increasing the atazanavir dose to 400 mg did not compensate for the impact of omeprazole on atazanavir exposure. The co-administration of omeprazole (20 mg once daily) with atazanavir 400 mg/ritonavir 100 mg to healthy volunteers resulted in a decrease of approximately 30% in the atazanavir exposure as compared to atazanavir 300 mg/ritonavir 100 mg once daily.

Digoxin

Concomitant treatment with omeprazole (20 mg daily) and digoxin in healthy subjects increased the bioavailability of digoxin by 10%. Digoxin toxicity has been rarely reported. However caution should be exercised when omeprazole is given at high doses in elderly patients. Therapeutic drug monitoring of digoxin should be then be reinforced.

Clopidogrel

Results from studies in healthy subjects have shown a pharmacokinetic (PK)/pharmacodynamic (PD) interaction between clopidogrel (300 mg loading dose/75 mg daily maintenance dose) and omeprazole (80 mg p.o. daily) resulting in a decreased exposure to the active metabolite of clopidogrel by an average of 46% and a decreased maximum inhibition of (ADP induced) platelet aggregation by an average of 16%.

Inconsistent data on the clinical implications of a PK/PD interaction of omeprazole in terms of major cardiovascular events have been reported from both observational and clinical studies. As a precaution, concomitant use of omeprazole and clopidogrel should be discouraged (see section 4.4).

Other active substances

The absorption of posaconazole, erlotinib, ketoconazole and itraconazole is significantly reduced and thus clinical efficacy may be impaired. For posaconazole and erlotinib concomitant use should be avoided.

Active substances metabolised by CYP2C19

Omeprazole is a moderate inhibitor of CYP2C19, the major omeprazole metabolising enzyme. Thus, the metabolism of concomitant active substances also metabolised by CYP2C19, may be decreased and the systemic exposure to these substances increased. Examples of such drugs are R-warfarin and other vitamin K antagonists, cilostazol, diazepam and phenytoin.

Cilostazol

Omeprazole, given in doses of 40 mg to healthy subjects in a cross-over study, increased C_{max} and AUC for cilostazol by 18% and 26% respectively, and one of its active metabolites by 29% and 69% respectively.

Phenytoin

Monitoring phenytoin plasma concentration is recommended during the first two weeks after initiating omeprazole treatment and, if a phenytoin dose adjustment is made, monitoring and a further dose adjustment should occur upon ending omeprazole treatment.

Unknown mechanism

Saquinavir

Concomitant administration of omeprazole with saquinavir/ritonavir resulted in increased plasma levels up to approximately 70% for saquinavir associated with good tolerability in HIV-infected patients.

Tacrolimus

Concomitant administration of omeprazole has been reported to increase the serum levels of tacrolimus. A reinforced monitoring of tacrolimus concentrations as well as renal function (creatinine clearance) should be performed, and dosage of tacrolimus adjusted if needed.

Methotrexate

When given together with proton-pump inhibitors, methotrexate levels have been reported to increase in some patients. In high-dose methotrexate administration a temporary withdrawal of omeprazole may need to be considered.

Effects of other active substances on the pharmacokinetics of omeprazole

Inhibitors CYP2C19 and/or CYP3A4

Since omeprazole is metabolised by CYP2C19 and CYP3A4, active substances known to inhibit CYP2C19 or CYP3A4 (such as clarithromycin and voriconazole) may lead to increased omeprazole serum levels by decreasing omeprazole's rate of metabolism. Concomitant voriconazole treatment resulted in more than doubling of the omeprazole exposure. As high doses of omeprazole have been well-tolerated adjustment of the omeprazole dose is not generally required. However, dose adjustment should be considered in patients with severe hepatic impairment and if long-term treatment is indicated.

Inducers of CYP2C19 and/or CYP3A4

Active substances known to induce CYP2C19 or CYP3A4 or both (such as rifampicin and St John's wort) may lead to decreased omeprazole serum levels by increasing omeprazole's rate of metabolism.

4.6 Fertility, pregnancy and lactation

Pregnancy

Results from three prospective epidemiological studies (more than 1000 exposed outcomes) indicate no adverse effects of omeprazole on pregnancy or on the health of the foetus/newborn child. Omeprazole can be used during pregnancy.

Breast-feeding

Omeprazole is excreted in breast milk but is not likely to influence the child when therapeutic doses are used.

Fertility

Animal studies with the racemic mixture omeprazole, given by oral administration do not indicate effects with respect to fertility.

4.7 Effects on ability to drive and use machines

Omeprazole Oral Suspension is not likely to affect the ability to drive or use machines. Adverse drug reactions such as dizziness and visual disturbances may occur (see section 4.8). If affected, patients should not drive or operate machinery.

4.8 Undesirable effects

Summary of the safety profile

The most common side effects (1-10% of patients) are headache, abdominal pain, constipation, diarrhoea, flatulence and nausea/vomiting.

Severe cutaneous adverse reactions (SCARs), including Stevens-Johnson syndrome (SJS), toxic epidermal necrolysis (TEN), drug reaction with eosinophilia and systemic symptoms (DRESS) and acute generalized exanthematous pustulosis (AGEP) have been reported in association with omeprazole treatment (see section 4.4).

Tabulated list of adverse reactions

The following adverse drug reactions have been identified or suspected in the clinical trials programme for omeprazole and post-marketing. None was found to be dose-related. Adverse reactions listed below are classified according to frequency and System Organ Class (SOC). Frequency categories are defined according to the following convention: Very common ($\geq 1/10$), Common ($\geq 1/100$ to $< 1/10$), Uncommon ($\geq 1/1,000$ to $< 1/100$), Rare ($\geq 1/10,000$ to $< 1/1,000$), Very rare ($< 1/10,000$), Not known (cannot be estimated from the available data).

SOC/frequency	Adverse reaction
Blood and lymphatic system disorders	
Rare:	Leukopenia, thrombocytopenia
Very rare:	Agranulocytosis, pancytopenia
Immune system disorders	
Rare:	Hypersensitivity reactions e.g. fever, angioedema and anaphylactic reaction/shock
Metabolism and nutrition disorders	
Rare:	Hyponatraemia
Not known:	Hypomagnesaemia; severe hypomagnesaemia may result in hypocalcaemia.

	Hypomagnesaemia may also be associated with hypokalaemia.
Psychiatric disorders	
Uncommon:	Insomnia
Rare:	Agitation, confusion, depression
Very rare:	Aggression, hallucinations
Nervous system disorders	
Common:	Headache
Uncommon:	Dizziness, paraesthesia, somnolence
Rare:	Taste disturbance
Eye disorders	
Rare:	Blurred vision
Ear and labyrinth disorders	
Uncommon:	Vertigo
Respiratory, thoracic and mediastinal disorders	
Rare:	Bronchospasm
Gastrointestinal disorders	
Common:	Abdominal pain, constipation, diarrhoea, flatulence, nausea/vomiting, fundic gland polyps (benign)
Rare:	Dry mouth, stomatitis, gastrointestinal candidiasis
Not known:	Microscopic colitis
Hepatobiliary disorders	
Uncommon:	Increased liver enzymes
Rare:	Hepatitis with or without jaundice
Very rare:	Hepatic failure, encephalopathy in patients with pre-existing liver disease
Skin and subcutaneous tissue disorders	
Uncommon:	Dermatitis, pruritus, rash, urticaria
Rare:	Alopecia, photosensitivity, acute generalized exanthematous pustulosis (AGEP), drug reaction with eosinophilia and systemic symptoms (DRESS)
Very rare:	Erythema multiforme, Stevens-Johnson syndrome, toxic epidermal necrolysis (TEN)
Not known:	Subacute cutaneous lupus erythematosus (see section 4.4)
Musculoskeletal and connective tissue disorders	
Uncommon:	Fracture of the hip, wrist or spine
Rare:	Arthralgia, myalgia
Very rare:	Muscular weakness
Renal and urinary disorders	
Rare:	Tubulointerstitial nephritis (with possible progression to renal failure)
Reproductive system and breast disorders	
Very rare:	Gynaecomastia
General disorders and administration site conditions	
Uncommon:	Malaise, peripheral oedema
Rare:	Increased sweating

Paediatric population

The safety of omeprazole has been assessed in a total of 310 children aged 0 to 16 years with acid-related disease. There are limited long term safety data from 46 children who received maintenance therapy of omeprazole during a clinical study for severe erosive esophagitis for up to 749 days. The adverse event profile was generally the same as for adults in short- as well as in long-term treatment. There are no long term data regarding the effects of omeprazole treatment on puberty and growth.

Reporting of suspected adverse reactions

Reporting suspected adverse reactions after authorisation of the medicinal product is important. It allows continued monitoring of the benefit/risk balance of the medicinal product. Healthcare professionals are asked to report any suspected adverse reactions via the Yellow Card Scheme. Website: www.mhra.gov.uk/yellowcard or search for MHRA Yellow Card in the Google Play or Apple App Store.

4.9 Overdose

There is limited information available on the effects of overdoses of omeprazole in humans. In the literature, doses of up to 560 mg have been described, and occasional reports have been received when single oral doses have reached up to 2,400 mg omeprazole (120 times the usual recommended clinical dose). Nausea, vomiting, dizziness, abdominal pain, diarrhoea and headache have been reported. Also apathy, depression and confusion have been described in single cases.

The symptoms described have been transient, and no serious outcome has been reported. The rate of elimination was unchanged (first order kinetics) with increased doses. Treatment, if needed, is symptomatic.

5 PHARMACOLOGICAL PROPERTIES

5.1 Pharmacodynamic properties

Pharmacotherapeutic group: Drugs for acid-related disorders, Proton pump inhibitors, ATC code: A02BC01

Mechanism of action

Omeprazole, a racemic mixture of two enantiomers reduces gastric acid secretion through a highly targeted mechanism of action. It is a specific inhibitor of the acid pump in the parietal cell. It is rapidly acting and provides control through reversible inhibition of gastric acid secretion with once daily dosing.

Omeprazole is a weak base and is concentrated and converted to the active form in the highly acidic environment of the intracellular canaliculi within the

parietal cell, where it inhibits the enzyme $H^+ K^+$ -ATPase - the acid pump. This effect on the final step of the gastric acid formation process is dose-dependent and provides for highly effective inhibition of both basal acid secretion and stimulated acid secretion, irrespective of stimulus.

Pharmacodynamic effects

All pharmacodynamic effects observed can be explained by the effect of omeprazole on acid secretion.

Effect on gastric acid secretion

Oral dosing with omeprazole once daily provides for rapid and effective inhibition of daytime and night-time gastric acid secretion with maximum effect being achieved within 4 days of treatment. With omeprazole 20 mg, a mean decrease of at least 80% in 24-hour intragastric acidity is then maintained in duodenal ulcer patients, with the mean decrease in peak acid output after pentagastrin stimulation being about 70% 24 hours after dosing.

Oral dosing with omeprazole 20 mg maintains an intragastric pH of ≥ 3 for a mean time of 17 hours of the 24-hour period in duodenal ulcer patients.

As a consequence of reduced acid secretion and intragastric acidity, omeprazole dose-dependently reduces/normalizes acid exposure of the esophagus in patients with gastro-esophageal reflux disease.

The inhibition of acid secretion is related to the area under the plasma concentration-time curve (AUC) of omeprazole and not to the actual plasma concentration at a given time.

No tachyphylaxis has been observed during treatment with omeprazole.

Effect on *H. pylori*

H. pylori is associated with peptic ulcer disease, including duodenal and gastric ulcer disease. *H. pylori* is a major factor in the development of gastritis. *H. pylori* together with gastric acid are major factors in the development of peptic ulcer disease. *H. pylori* is a major factor in the development of atrophic gastritis which is associated with an increased risk of developing gastric cancer.

Eradication of *H. pylori* with omeprazole and antimicrobials is associated with, high rates of healing and long-term remission of peptic ulcers.

Dual therapies have been tested and found to be less effective than triple therapies. They could, however, be considered in cases where known hypersensitivity precludes use of any triple combination.

Other effects related to acid inhibition

During long-term treatment gastric glandular cysts have been reported in a somewhat increased frequency. These changes are a physiological consequence of pronounced inhibition of acid secretion, are benign and appear to be reversible.

Decreased gastric acidity due to any means including proton pump inhibitors, increases gastric counts of bacteria normally present in the gastrointestinal tract. Treatment with acid-reducing drugs may lead to slightly increased risk of gastrointestinal infections such as *Salmonella* and *Campylobacter* and, in hospitalised patients, possibly also *Clostridium difficile*.

During treatment with antisecretory medicinal products, serum gastrin increases in response to the decreased acid secretion. Also CgA increases due to decreased gastric acidity. The increased CgA level may interfere with investigations for neuroendocrine tumours. Available published evidence suggests that proton pump inhibitors should be discontinued between 5 days and 2 weeks prior to CgA measurements. This is to allow CgA levels that might be spuriously elevated following PPI treatment to return to reference range.

An increased number of ECL cells possibly related to the increased serum gastrin levels, have been observed in some patients (both children and adults) during long term treatment with omeprazole. The findings are considered to be of no clinical significance.

Paediatric population

In a non-controlled study in children (1 to 16 years of age) with severe reflux esophagitis, omeprazole at doses of 0.7 to 1.4 mg/kg improved esophagitis level in 90% of the cases and significantly reduced reflux symptoms. In a single-blind study, children aged 0–24 months with clinically diagnosed gastro-esophageal reflux disease were treated with 0.5, 1.0 or 1.5 mg omeprazole/kg. The frequency of vomiting/regurgitation episodes decreased by 50% after 8 weeks of treatment irrespective of the dose.

Eradication of *H. pylori* in children

A randomised, double blind clinical study (Héliot study) concluded that omeprazole in combination with two antibiotics (amoxicillin and clarithromycin), was safe and effective in the treatment of *H. pylori* infection in children age 4 years old and above with gastritis: *H. pylori* eradication rate:

74.2% (23/31 patients) with omeprazole + amoxicillin + clarithromycin versus 9.4% (3/32 patients) with amoxicillin + clarithromycin. However, there was no evidence of any clinical benefit with respect to dyspeptic symptoms. This study does not support any information for children aged less than 4 years.

5.2 Pharmacokinetic properties

Absorption

Omeprazole is acid labile and is therefore administered in Omeprazole Oral Suspension as a buffered suspension. The buffer protects omeprazole from acid degradation, facilitating absorption. Absorption of omeprazole is rapid, with peak plasma levels occurring approximately 30 minutes after dose. Absorption of omeprazole takes place in the small intestine and is usually completed within 3-6 hours. In a bioavailability study the administration with food (milk) reduced the extent of absorption by approximately 20%. The systemic availability (bioavailability) from a single oral dose of omeprazole is approximately 40%. After repeated once-daily administration, the bioavailability increases to about 60%.

Distribution

The apparent volume of distribution in healthy subjects is approximately 0.3 l/kg body weight. Omeprazole is 97% plasma protein bound.

Biotransformation

Omeprazole is completely metabolised by the cytochrome P450 system (CYP). The major part of its metabolism is dependent on the polymorphically expressed CYP2C19, responsible for the formation of hydroxyomeprazole, the major metabolite in plasma. The remaining part is dependent on another specific isoform, CYP3A4, responsible for the formation of omeprazole sulphone. As a consequence of high affinity of omeprazole to CYP2C19, there is a potential for competitive inhibition and metabolic drug-drug interactions with other substrates for CYP2C19. However, due to low affinity to CYP3A4, omeprazole has no potential to inhibit the metabolism of other CYP3A4 substrates. In addition, omeprazole lacks an inhibitory effect on the main CYP enzymes.

Approximately 3% of the Caucasian population and 15-20% of Asian populations lack a functional CYP2C19 enzyme and are called poor metabolisers. In such individuals the metabolism of omeprazole is probably mainly catalysed by CYP3A4. After repeated once-daily administration of 20 mg omeprazole, the mean AUC was 5 to 10 times higher in poor metabolisers than in subjects having a functional CYP2C19 enzyme (extensive metabolisers). Mean peak plasma concentrations were also higher, by 3 to 5 times. These findings have no implications for the posology of omeprazole.

Elimination

The plasma elimination half-life of omeprazole is usually shorter than one hour both after single and repeated oral once-daily dosing. Omeprazole is completely eliminated from plasma between doses with no tendency for accumulation during once-daily administration. Almost 80% of an oral dose of omeprazole is excreted as metabolites in the urine, the remainder in the faeces, primarily originating from bile secretion.

Linearity/non-linearity

The AUC of omeprazole increases with repeated administration. This increase is dose-dependent and results in a non-linear dose-AUC relationship after repeated administration. This time- and dose-dependency is due to a decrease of first pass metabolism and systemic clearance probably caused by an inhibition of the CYP2C19 enzyme by omeprazole and/or its metabolites (e.g. the sulphone).

No metabolite has been found to have any effect on gastric acid secretion.

Special populations

Hepatic impairment

The metabolism of omeprazole in patients with liver dysfunction is impaired, resulting in an increased AUC. Omeprazole has not shown any tendency to accumulate with once daily dosing.

Renal impairment

The pharmacokinetics of omeprazole, including systemic bioavailability and elimination rate, are unchanged in patients with reduced renal function.

Elderly

The metabolism rate of omeprazole is somewhat reduced in elderly subjects (75-79 years of age).

Paediatric population

During treatment with the recommended doses to children from the age of 1 year, similar plasma concentrations were obtained as compared to adults. In children younger than 6 months, clearance of omeprazole is low due to low capacity to metabolise omeprazole.

5.3 Preclinical safety data

Gastric ECL-cell hyperplasia and carcinoids, have been observed in life-long studies in rats treated with omeprazole. These changes are the result of sustained hypergastrinaemia secondary to acid inhibition. Similar findings have been made after treatment with H₂-receptor antagonists, proton pump inhibitors and after partial fundectomy. Thus, these changes are not from a direct effect of any individual active substance.

6 PHARMACEUTICAL PARTICULARS

6.1 List of excipients

Sodium hydrogen carbonate (E500)

Potassium hydrogen carbonate (E501)

Sodium alginate (E401)

Maltitol (E965)

Mannitol (E421)

Sucralose (E955)

Xanthan gum (E415)

Natural Mint Flavouring containing Gum Arabic / Acacia Gum (E414), pulegone

Titanium dioxide (E171)

Sodium benzoate (E211)

Sodium methyl parahydroxybenzoate (E219)

6.2 Incompatibilities

Not applicable.

6.3 Shelf life

Dry Powders: 24 months.

Constituted suspension: 28 days.

The constituted suspension should be stored in a refrigerator (2°C - 8°C). Store in the original container in order to protect from light. Keep the bottle tightly closed. For up to 2 days it may be stored below 25°C.

6.4 Special precautions for storage

Dry Powders: Do not store above 25°C. Store in the original foil pouch in order to protect from light and moisture.

For storage conditions after reconstitution of the medicinal product, see section 6.3.

6.5 Nature and contents of container

Amber plastic (PET) bottle with powder fitted with a red Polypropylene (PP) closure cap containing powder, all enclosed in an aluminium foil pouch.

Each bottle contains 47 g of powder for oral suspension. Once constituted the bottle contains 90 ml of oral suspension, of which 75 ml is intended for dosing and administration.

Each pack also contains an opaque PP oral dosing syringe (5 ml, graduated at each 1ml and intermediate marks every 0.1ml) with white HDPE plunger, colourless, transparent LDPE bottle adaptor and grey PP replacement cap.

Pack: 1 or 2 bottles.

Not all pack sizes may be marketed.

6.6 Special precautions for disposal

It is recommended that a pharmacist constitutes Omeprazole Oral Suspension prior to its dispensing to the patient

Preparing and taking the suspension

The container is a two compartment system containing powder both in the cap and in the bottle. The two powders first need to be combined and are then to be constituted in water. A red mixing disk will drop into the medicine to help mix the powders and also mix the constituted suspension after addition of the water. It should remain in the bottle. The red cap is replaced by a grey cap after constitution.

Instructions for initial constitution.

Combination of powder in cap and bottle

- Shake the bottle for 10 seconds to loosen the powder.
- Twist the red cap anti-clockwise (see arrow on cap) until the seal is broken to release the powder in the red cap into the bottle.
- Twist the red cap back to the original position, securely fastening the red cap onto the bottle.

Constitution of the powder

- Shake the bottle vigorously for ten seconds to mix the powders.
- Tap the base of the bottle three times on a hard horizontal surface to make sure all powder is in the bottle and not in the cap.
- Remove the red cap from the bottle.

- Add 64ml of water by using a suitable measuring device up to the line on the label.
- Securely fasten the red cap onto the bottle and shake vigorously for 30 seconds.

Placement of syringe adaptor

- Remove the red cap and red ring and throw away.
- Insert the colourless, transparent Bottle Adaptor and replace the red cap with the grey plastic screw-cap.
- Leave for fifteen minutes for product to reach final consistency.

The reconstituted suspension will be a white / off-white / brownish suspension. It may contain dark specks due to the sweetener.

Measuring your dose

Instructions for use of the syringe

1. Shake for 20 seconds immediately prior to each use.
2. To open the bottle, press the grey cap down and turn it anti-clockwise (Figure 1). Do not remove the white cap portion.
3. Take the syringe and put it into the adaptor opening (Figure 2).
4. Turn the bottle upside down (Figure 3).
5. Fill the syringe with a small amount of suspension by pulling the plunger down (Figure 4A). Then push the plunger upward in order to remove any possible bubbles (Figure 4B). Finally, pull the plunger down to the graduation mark corresponding to the quantity in millilitres (ml) prescribed by your doctor. The top flat edge of the piston should be in line with the graduation mark you are measuring to (Figure 4C).
6. Turn the bottle the right way up (Figure 5A).
7. Remove the syringe from the adaptor (Figure 5B).
8. Put the end of the syringe into the mouth of the patient and push the plunger slowly back in to take the medicine. The suspension will be released slowly while the last portion will be released faster due to reduced resistance in the tip of the syringe.
9. Wash the syringe with water and let it dry before you use it again (Figure 6).
10. Close the bottle with the grey plastic screw cap - leave the bottle adaptor in the bottle.

Note: It is normal to have the red plastic disc in the suspension during use; do not attempt to remove it.

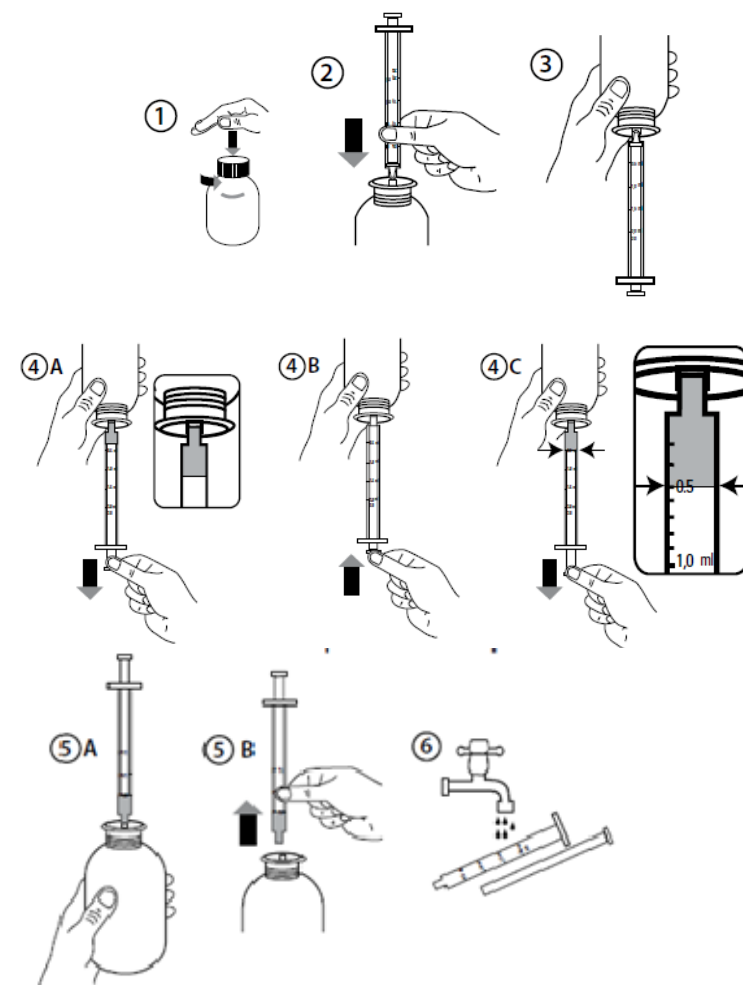

Instruction for administration via nasogastric (NG) or percutaneous endoscopic gastrostomy (PEG) tubes:

Ensure that the enteral feeding tube is free from obstruction before administration.

1. Flush the enteral tube with 5mL of water
2. Administer the required dose of Omeprazole Oral Suspension with a suitable measuring device.
3. Flush the enteral tube with 5mL of water

This product is compatible for use with Polyurethane and PVC nasogastric (NG) and percutaneous endoscopic gastrostomy (PEG) tubes of size 6 Fr to 16 Fr.

Any unused medicinal product or waste material should be disposed of in accordance with local requirements.

7 MARKETING AUTHORISATION HOLDER

Xeolas Pharmaceuticals Limited,
Hamilton Building,
DCU, Glasnevin,

Dublin 9,
IRELAND.

8 MARKETING AUTHORISATION NUMBER(S)

PL 34111/0003

**9 DATE OF FIRST AUTHORISATION/RENEWAL OF THE
AUTHORISATION**

01/10/2024

10 DATE OF REVISION OF THE TEXT

30/05/2023