

## **SUMMARY OF PRODUCT CHARACTERISTICS**

### **1 NAME OF THE MEDICINAL PRODUCT**

Olatuton 10 mg Powder and Solvent for Prolonged-release Suspension for Injection

### **2 QUALITATIVE AND QUANTITATIVE COMPOSITION**

Each vial contains octreotide acetate equivalent to 10 mg octreotide

For the full list of excipients, see section 6.1.

### **3 PHARMACEUTICAL FORM**

Powder and solvent for prolonged-release suspension for injection.

Powder: White to off-white powder, free of foreign particles.

Solvent: Clear, colourless solution, practically free from particles.

### **4 CLINICAL PARTICULARS**

#### **4.1 Therapeutic indications**

Treatment of patients with acromegaly in whom surgery is inappropriate or ineffective, or in the interim period until radiotherapy becomes fully effective (see section 4.2).

Treatment of patients with symptoms associated with functional gastro-entero-pancreatic endocrine tumours e.g. carcinoid tumours with features of the carcinoid syndrome (see section 5.1).

Treatment of patients with advanced neuroendocrine tumours of the midgut or of unknown primary origin where non-midgut sites of origin have been excluded.

Treatment of TSH-secreting pituitary adenomas:

- when secretion has not normalised after surgery and/or radiotherapy;
- in patients in whom surgery is inappropriate;

- in irradiated patients, until radiotherapy is effective.

## 4.2 Posology and method of administration

### Posology

#### Acromegaly

It is recommended to start treatment with the administration of 20 mg Olatuton at 4-week intervals for 3 months. Patients on treatment with s.c. octreotide can start treatment with Olatuton the day after the last dose of s.c. octreotide.

Subsequent dosage adjustment should be based on serum growth hormone (GH) and insulin-like growth factor 1/somatomedin C (IGF-1) concentrations and clinical symptoms.

For patients in whom, within this 3-month period, clinical symptoms and biochemical parameters (GH; IGF-1) are not fully controlled (GH concentrations still above 2.5 microgram/L), the dose may be increased to 30 mg every 4 weeks. If after 3 months, GH, IGF-1, and/or symptoms are not adequately controlled at a dose of 30 mg, the dose may be increased to 40 mg every 4 weeks.

For patients whose GH concentrations are consistently below 1 microgram/L, whose IGF-1 serum concentrations normalised, and in whom most reversible signs/symptoms of acromegaly have disappeared after 3 months of treatment with 20 mg, 10 mg Olatuton may be administered every 4 weeks. However, particularly in this group of patients, it is recommended to closely monitor adequate control of serum GH and IGF-1 concentrations, and clinical signs/symptoms at this low dose of Olatuton.

For patients on a stable dose of Olatuton, assessment of GH and IGF-1 should be made every 6 months.

#### Gastro-entero-pancreatic endocrine tumours

##### *Treatment of patients with symptoms associated with functional gastro-entero-pancreatic neuroendocrine tumours*

It is recommended to start treatment with the administration of 20 mg Olatuton at 4-week intervals. Patients on treatment with s.c. octreotide should continue at the previously effective dosage for 2 weeks after the first injection of Olatuton.

For patients in whom symptoms and biological markers are well controlled after 3 months of treatment, the dose may be reduced to 10 mg Olatuton every 4 weeks.

For patients in whom symptoms are only partially controlled after 3 months of treatment, the dose may be increased to 30 mg Olatuton every 4 weeks.

For days when symptoms associated with gastro-entero-pancreatic tumours may increase during treatment with Olatuton, additional administration of s.c. octreotide is recommended at the dose used prior to the Olatuton treatment. This may occur mainly in the first 2 months of treatment until therapeutic concentrations of octreotide are reached.

*Treatment of patients with advanced neuroendocrine tumours of the midgut or of unknown primary origin where non-midgut sites of origin have been excluded*

The recommended dose of Olatuton is 30 mg administered every 4 weeks (see section 5.1). Treatment with Olatuton for tumour control should be continued in the absence of tumour progression.

*Treatment of TSH-secreting adenomas*

Treatment with Olatuton should be started at a dose of 20 mg at 4-weekly intervals for 3 months before considering dose adjustment. The dose is then adjusted on the basis of the TSH and thyroid hormone response.

*Use in patients with impaired renal function*

Impaired renal function did not affect the total exposure (AUC) to octreotide when administered s.c. Therefore, no dose adjustment of Olatuton is necessary.

*Use in patients with impaired hepatic function*

In a study with octreotide administered s.c. and i.v. it was shown that the elimination capacity may be reduced in patients with liver cirrhosis, but not in patients with fatty liver disease. In certain cases patients with impaired hepatic function may require dose adjustment.

*Use in the elderly*

In a study with octreotide administered s.c., no dose adjustment was necessary in subjects  $\geq 65$  years of age. Therefore, no dose adjustment is necessary in this group of patients with Olatuton.

*Use in children*

There is limited experience with the use of Olatuton in children.

**Method of administration**

Olatuton may only be administered by deep intramuscular injection. The site of repeat intramuscular injections should be alternated between the left and right gluteal muscle (see section 6.6).

### 4.3 Contraindications

Hypersensitivity to the active substance or to any of the excipients listed in section 6.1.

### 4.4 Special warnings and precautions for use

#### General

As GH-secreting pituitary tumours may sometimes expand, causing serious complications (e.g. visual field defects), it is essential that all patients be carefully monitored. If evidence of tumour expansion appears, alternative procedures may be advisable.

The therapeutic benefits of a reduction in growth hormone (GH) levels and normalisation of insulin-like growth factor 1 (IGF-1) concentration in female acromegalic patients could potentially restore fertility. Female patients of childbearing potential should be advised to use adequate contraception if necessary during treatment with octreotide (see section 4.6).

Thyroid function should be monitored in patients receiving prolonged treatment with octreotide.

Hepatic function should be monitored during octreotide therapy.

#### Cardiovascular related events

Common cases of bradycardia have been reported. Dose adjustment of medicinal products such as beta blockers, calcium channel blockers, or agents to control fluid and electrolyte balance, may be necessary (see section 4.5).

#### Gallbladder and related events

Cholelithiasis is a very common event during octreotide treatment and may be associated with cholecystitis and biliary duct dilatation (see section 4.8).

Additionally, cases of cholangitis have been reported as a complication of cholelithiasis in patients taking octreotide prolonged-release injection in the post-marketing setting.

Ultrasonic examination of the gallbladder before and at about 6-monthly intervals during octreotide prolonged-release injection therapy is recommended.

#### Glucose metabolism

Because of its inhibitory action on growth hormone, glucagon, and insulin release, Olatuton may affect glucose regulation. Post-prandial glucose tolerance may be impaired. As reported for patients treated with s.c. octreotide, in some instances, the state of persistent hyperglycaemia may be induced as a result of chronic administration. Hypoglycaemia has also been reported.

In patients with concomitant Type I diabetes mellitus, Olatuton is likely to affect glucose regulation, and insulin requirements may be reduced. In non-diabetics and type II diabetics with partially intact insulin reserves, octreotide s.c. administration may result in increases in post-prandial glycaemia. It is therefore recommended to monitor glucose tolerance and antidiabetic treatment.

In patients with insulinomas, octreotide, because of its greater relative potency in inhibiting the secretion of GH and glucagon than that of insulin, and because of the shorter duration of its inhibitory action on insulin, may increase the depth and prolong the duration of hypoglycaemia. These patients should be closely monitored.

#### Pancreatic function

Pancreatic exocrine insufficiency (PEI) has been observed in some patients receiving octreotide therapy for gastroenteropancreatic neuroendocrine tumours. Symptoms of PEI can include steatorrhea, loose stools, abdominal bloating and weight loss. Screening and appropriate treatment for PEI according to clinical guidelines should be considered in symptomatic patients.

#### Nutrition

Octreotide may alter absorption of dietary fats in some patients.

Depressed vitamin B12 levels and abnormal Schilling's tests have been observed in some patients receiving octreotide therapy. Monitoring of vitamin B12 levels is recommended during therapy with Olatuton in patients who have a history of vitamin B12 deprivation.

#### Sodium content

Olatuton contains less than 1 mmol (23 mg) sodium per dose, that is to say essentially 'sodium-free'.

### **4.5 Interaction with other medicinal products and other forms of interaction**

Dose adjustment of medicinal products such as beta blockers, calcium channel blockers, or agents to control fluid and electrolyte balance may be necessary when Olatuton is administered concomitantly (see section 4.4).

Dose adjustments of insulin and antidiabetic medicinal products may be required when Olatuton is administered concomitantly (see section 4.4).

Octreotide has been found to reduce the intestinal absorption of ciclosporin and to delay that of cimetidine.

Concomitant administration of octreotide and bromocriptine increases the bioavailability of bromocriptine.

Limited published data indicate that somatostatin analogues might decrease the metabolic clearance of compounds known to be metabolised by cytochrome P450 enzymes, which may be due to the suppression of growth hormone. Since it cannot be excluded that octreotide may have this effect, other drugs mainly metabolised by CYP3A4 and which have a low therapeutic index (e.g. quinidine, terfenadine) should therefore be used with caution.

#### Concomitant use with radioactive somatostatin analogues

Somatostatin and its analogues such as octreotide competitively bind to somatostatin receptors and may interfere with the efficacy of radioactive somatostatin analogues. The administration of Olatuton should be avoided for at least 4 weeks prior to the

administration of lutetium ( $^{177}\text{Lu}$ ) oxodotreotide, a radiopharmaceutical binding to somatostatin receptors. If necessary, patients may be treated with short acting somatostatin analogues until 24 hours prior to the administration of lutetium ( $^{177}\text{Lu}$ ) oxodotreotide.

After administration of lutetium ( $^{177}\text{Lu}$ ) oxodotreotide, treatment with Olatuton can be resumed within 4 to 24 hours and should be discontinued again 4 weeks prior to the next administration of lutetium ( $^{177}\text{Lu}$ ) oxodotreotide.

## **4.6 Fertility, pregnancy and lactation**

### Pregnancy

There is a limited amount of data (less than 300 pregnancy outcomes) from the use of octreotide in pregnant women, and in approximately one third of the cases the pregnancy outcomes are unknown. The majority of reports were received after post-marketing use of octreotide and more than 50% of exposed pregnancies were reported in patients with acromegaly. Most women were exposed to octreotide during the first trimester of pregnancy at doses ranging from 100-1200 micrograms/day of octreotide s.c. or 10-40 mg/month of octreotide long-acting injection. Congenital anomalies were reported in about 4% of pregnancy cases for which the outcome is known. No causal relationship to octreotide is suspected for these cases.

Animal studies do not indicate direct or indirect harmful effects with respect to reproductive toxicity (see section 5.3).

As a precautionary measure, it is preferable to avoid the use of Olatuton during pregnancy (see section 4.4).

### Breast-feeding

It is unknown whether octreotide is excreted in human breast milk. Animal studies have shown excretion of octreotide in breast milk. Patients should not breast-feed during Olatuton treatment.

### Fertility

It is not known whether octreotide has an effect on human fertility. Late descent of the testes was found for male offsprings of dams treated during pregnancy and lactation. Octreotide, however, did not impair fertility in male and female rats at doses of up to 1 mg/kg body weight per day (see section 5.3).

## **4.7 Effects on ability to drive and use machines**

Olatuton has no or negligible influence on the ability to drive and use machines. Patients should be advised to be cautious when driving or using machines if they experience dizziness, asthenia/fatigue, or headache during treatment with Olatuton.

## 4.8 Undesirable effects

### Summary of the safety profile

The most frequent adverse reactions reported during octreotide therapy include gastrointestinal disorders, nervous system disorders, hepatobiliary disorders, and metabolism and nutritional disorders.

The most commonly reported adverse reactions in clinical trials with octreotide administration were diarrhoea, abdominal pain, nausea, flatulence, headache, cholelithiasis, hyperglycaemia and constipation. Other commonly reported adverse reactions were dizziness, localised pain, biliary sludge, thyroid dysfunction (e.g., decreased thyroid stimulating hormone [TSH], decreased total T4, and decreased free T4), loose stools, impaired glucose tolerance, vomiting, asthenia, and hypoglycaemia.

### Tabulated list of adverse reactions

The following adverse drug reactions, listed in Table 1, have been accumulated from clinical studies with octreotide:

Adverse drug reactions (Table 1) are ranked under heading of frequency, the most frequent first, using the following convention: very common ( $\geq 1/10$ ); common ( $\geq 1/100$ ,  $< 1/10$ ); uncommon ( $\geq 1/1,000$ ,  $< 1/100$ ); rare ( $\geq 1/10,000$ ,  $< 1/1,000$ ) very rare ( $< 1/10,000$ ), including isolated reports. Within each frequency grouping, adverse reactions are ranked in order of decreasing seriousness.

**Table 1: Adverse drug reactions reported in clinical studies**

<b>Gastrointestinal disorders</b>	
Very common:	Diarrhoea, abdominal pain, nausea, constipation, flatulence.
Common:	Dyspepsia, vomiting, abdominal bloating, steatorrhoea, loose stools, discolouration of faeces.
<b>Nervous system disorders</b>	
Very common:	Headache.
Common:	Dizziness.
<b>Endocrine disorders</b>	
Common:	Hypothyroidism, thyroid disorder (e.g., decreased TSH, decreased total T4, and decreased free T4).
<b>Hepatobiliary disorders</b>	
Very common:	Cholelithiasis.
Common:	Cholecystitis, biliary sludge, hyperbilirubinaemia.
<b>Metabolism and nutrition disorders</b>	
Very common:	Hyperglycaemia.
Common:	Hypoglycaemia, impaired glucose tolerance, anorexia.
Uncommon:	Dehydration.

<b>General disorders and administration site conditions</b>	
Very common:	Injection site reactions.
Common:	Asthenia.
<b>Investigations</b>	
Common:	Elevated transaminase levels.
<b>Skin and subcutaneous tissue disorders</b>	
Common:	Pruritus, rash, alopecia.
<b>Respiratory, thoracic and mediastinal disorders</b>	
Common:	Dyspnoea.
<b>Cardiac disorders</b>	
Common:	Bradycardia.
Uncommon:	Tachycardia.

#### Post-marketing

Spontaneously reported adverse reactions, presented in Table 2, are reported voluntarily and it is not always possible to reliably establish frequency or a causal relationship to drug exposure.

**Table 2: Adverse drug reactions derived from spontaneous reports**

<b>Blood and lymphatic system disorders</b>
Thrombocytopenia.
<b>Immune system disorders</b>
Anaphylaxis, allergy/hypersensitivity reactions.
<b>Skin and subcutaneous tissue disorders</b>
Urticaria.
<b>Hepatobiliary disorders</b>
Acute pancreatitis, acute hepatitis without cholestasis, cholestatic hepatitis, cholestasis, jaundice, cholestatic jaundice.
<b>Cardiac disorders</b>
Arrhythmias.
<b>Investigations</b>
Increased alkaline phosphatase levels, increased gamma glutamyl transferase levels.

#### Description of selected adverse reactions

##### *Gallbladder and related reactions*

Somatostatin analogues have been shown to inhibit gallbladder contractility and decrease bile secretion, which may lead to gallbladder abnormalities or sludge. Development of gallstones has been reported in 15 to 30% of long-term recipients of s.c. octreotide. The incidence in the general population (aged 40 to 60 years) is about 5 to 20%. Long-term exposure to octreotide prolonged-release injection of patients with acromegaly or gastro-entero-pancreatic tumours suggests that treatment with octreotide prolonged-release injection does not increase the incidence of gallstone formation, compared with s.c. treatment. If gallstones do occur, they are usually asymptomatic; symptomatic stones should be treated either by dissolution therapy with bile acids or by surgery.

##### *Gastrointestinal disorders*

In rare instances, gastrointestinal side effects may resemble acute intestinal obstruction, with progressive abdominal distension, severe epigastric pain, abdominal tenderness and guarding.

The frequency of gastrointestinal adverse events is known to decrease over time with continued treatment.

#### *Hypersensitivity and anaphylactic reactions*

Hypersensitivity and allergic reactions have been reported during post-marketing. When these occur, they mostly affect the skin, rarely the mouth and airways. Isolated cases of anaphylactic shock have been reported.

#### *Injection site reactions*

Injection site related reactions including pain, redness, haemorrhage, pruritus, swelling or induration were commonly reported in patients receiving octreotide prolonged-release injection; however, these events did not require any clinical intervention in the majority of the cases.

#### *Metabolism and nutrition disorders*

Although measured faecal fat excretion may increase, there is no evidence to date that long-term treatment with octreotide has led to nutritional deficiency due to malabsorption.

#### *Pancreatic enzymes*

In very rare instances, acute pancreatitis has been reported within the first hours or days of octreotide s.c. treatment and resolved on withdrawal of the drug. In addition, cholelithiasis-induced pancreatitis has been reported for patients on long-term octreotide s.c. treatment.

#### *Cardiac disorders*

Bradycardia is a common adverse reaction with somatostatin analogues. In both acromegalic and carcinoid syndrome patients, ECG changes were observed such as QT prolongation, axis shifts, early repolarisation, low voltage, R/S transition, early R wave progression, and non-specific ST-T wave changes. The relationship of these events to octreotide acetate is not established because many of these patients have underlying cardiac diseases (see section 4.4).

#### *Thrombocytopenia*

Thrombocytopenia has been reported during post-marketing experience, particularly during treatment with octreotide prolonged-release injection (i.v.) in patients with cirrhosis of the liver, and during treatment with octreotide injection. This is reversible after discontinuation of treatment.

#### Reporting of suspected adverse reactions

Reporting suspected adverse reactions after authorisation of the medicinal product is important. It allows continued monitoring of the benefit/risk balance of the medicinal product. Healthcare professionals are asked to report any suspected adverse reactions via the Yellow Card Scheme Website: [www.mhra.gov.uk/yellowcard](http://www.mhra.gov.uk/yellowcard) or search for MHRA Yellow Card in the Google Play or Apple App Store.

## **4.9 Overdose**

A limited number of accidental overdoses of octreotide prolonged-release injection have been reported. The doses ranged from 100 mg to 163 mg/month of octreotide prolonged-release injection. The only adverse event reported was hot flushes.

Cancer patients receiving doses of octreotide prolonged-release injection up to 60 mg/month and up to 90 mg/2 weeks have been reported. These doses were in general well tolerated; however, the following adverse events have been reported: frequent urination, fatigue, depression, anxiety, and lack of concentration.

The management of overdosage is symptomatic.

## **5 PHARMACOLOGICAL PROPERTIES**

### **5.1 Pharmacodynamic properties**

Pharmacotherapeutic group: Somatostatin and analogues, ATC code: H01CB02

#### Mechanism of action

Octreotide is a synthetic octapeptide derivative of naturally occurring somatostatin with similar pharmacological effects, but with a considerably prolonged duration of action. It inhibits pathologically increased secretion of growth hormone (GH) and of peptides and serotonin produced within the GEP endocrine system.

In animals, octreotide is a more potent inhibitor of GH, glucagon and insulin release than somatostatin is, with greater selectivity for GH and glucagon suppression.

In healthy subjects octreotide, like somatostatin, has been shown to inhibit:

- Release of GH stimulated by arginine, exercise- and insulin-induced hypoglycaemia,
- Post-prandial release of insulin, glucagon, gastrin, other peptides of the GEP endocrine system, and arginine-stimulated release of insulin and glucagon,
- thyrotropin-releasing hormone (TRH)-stimulated release of thyroid-stimulating hormone (TSH).

Unlike somatostatin, octreotide inhibits GH secretion preferentially over insulin and its administration is not followed by rebound hypersecretion of hormones (i.e. GH in patients with acromegaly).

In patients with acromegaly, Olatuton, a galenical formulation of octreotide suitable for repeated administration at intervals of 4 weeks, delivers consistent and therapeutic octreotide serum concentrations thus consistently lowering GH and normalising IGF 1 serum concentrations in the majority of patients. In most patients, octreotide prolonged-release injection markedly reduces the clinical symptoms of the disease, such as headache, perspiration, paraesthesia, fatigue, osteoarthralgia and carpal tunnel syndrome. In previously untreated acromegaly patients with GH-secreting pituitary adenoma, octreotide prolonged-release injection treatment resulted in a tumour volume reduction of >20% in a significant proportion (50%) of patients.

In individual patients with GH-secreting pituitary adenoma, octreotide prolonged-release injection was reported to lead to shrinkage of the tumour (prior to surgery). However, surgery should not be delayed.

For patients with functional tumours of the gastro-entero-pancreatic endocrine system, treatment with Olatuton provides continuous control of symptoms related to the underlying disease. The effect of octreotide in different types of gastro-entero-pancreatic tumours are as follows:

#### Carcinoid tumours

Administration of octreotide may result in improvement of symptoms, particularly of flushing and diarrhoea. In many cases, this is accompanied by a fall in plasma serotonin and reduced urinary excretion of 5 hydroxyindole acetic acid.

#### VIPomas

The biochemical characteristic of these tumours is overproduction of vasoactive intestinal peptide (VIP). In most cases, administration of octreotide results in alleviation of the severe secretory diarrhoea typical of the condition, with consequent improvement in quality of life. This is accompanied by an improvement in associated electrolyte abnormalities, e.g. hypokalaemia, enabling enteral and parenteral fluid and electrolyte supplementation to be withdrawn. In some patients, computed tomography scanning suggests a slowing or arrest of progression of the tumour, or even tumour shrinkage, particularly of hepatic metastases. Clinical improvement is usually accompanied by a reduction in plasma VIP levels, which may fall into the normal reference range.

#### Glucagonomas

Administration of octreotide results in most cases in substantial improvement of the necrolytic migratory rash which is characteristic of the condition. The effect of octreotide on the state of mild diabetes mellitus which frequently occurs is not marked and, in general, does not result in a reduction of requirements for insulin or oral hypoglycaemic agents. Octreotide produces improvement of diarrhoea, and hence weight gain, in those patients affected. Although administration of octreotide often leads to an immediate reduction in plasma glucagon levels, this decrease is generally not maintained over a prolonged period of administration, despite continued symptomatic improvement.

#### Gastrinomas/Zollinger-Ellison syndrome

Therapy with proton pump inhibitors or H<sub>2</sub> receptor blocking agents generally controls gastric acid hypersecretion. However, diarrhoea, which is also a prominent symptom, may not be adequately alleviated by proton pump inhibitors or H<sub>2</sub> receptor blocking agents. Olatuton can help to further reduce gastric acid hypersecretion and improve symptoms, including diarrhoea, as it provides suppression of elevated gastrin levels, in some patients.

#### Insulinomas

Administration of octreotide produces a fall in circulating immunoreactive insulin. In patients with operable tumours, octreotide may help to restore and maintain normoglycemia pre-operatively. In patients with inoperative benign or malignant tumours, glycaemic control may be improved even without concomitant sustained reduction in circulating insulin levels.

#### Advanced neuroendocrine tumours of the midgut or of unknown primary origin where non-midgut sites of origin have been excluded

A Phase III, randomised, double-blind, placebo-controlled study (PROMID) demonstrated that octreotide prolonged-release injection inhibits tumour growth in patients with advanced neuroendocrine tumours of the midgut. 85 patients were

randomised to receive octreotide prolonged-release injection 30 mg every 4 weeks (n=42) or placebo (n=43) for 18 months, or until tumour progression or death.

Main inclusion criteria were: treatment naïve; histologically confirmed; locally inoperable or metastatic well-differentiated; functionally active or inactive neuroendocrine tumours/carcinomas; with primary tumour located in the midgut or unknown origin believed to be of midgut origin if a primary within the pancreas, chest, or elsewhere was excluded.

The primary endpoint was time to tumour progression or tumour-related death (TTP).

In the intent-to-treat analysis population (ITT) (all randomised patients), 26 and 41 progressions or tumour-related deaths were seen in the octreotide prolonged-release injection and placebo groups, respectively (HR = 0.32; 95% CI, 0.19 to 0.55; p-value =.000015).

In the conservative ITT (cITT) analysis population in which 3 patients were censored at randomization, 26 and 40 progressions or tumour-related deaths were observed in the octreotide prolonged-release injection and placebo groups, respectively (HR=0.34; 95% CI, 0.20 to 0.59; p-value =.000072; Fig 1). Median time to tumour progression was 14.3 months (95% CI, 11.0 to 28.8 months) in the octreotide prolonged-release injection group and 6.0 months (95% CI, 3.7 to 9.4 months) in the placebo group.

In the per-protocol analysis population (PP) in which additional patients were censored at end study therapy, tumour progression or tumour-related death was observed in 19 and 38 octreotide prolonged-release injection and placebo recipients, respectively (HR = 0.24; 95% CI, 0.13 to 0.45; p-value =.0000036).

**Figure 1 Kaplan-Meier estimates of TTP comparing octreotide prolonged-release injection with placebo (conservative ITT population)**

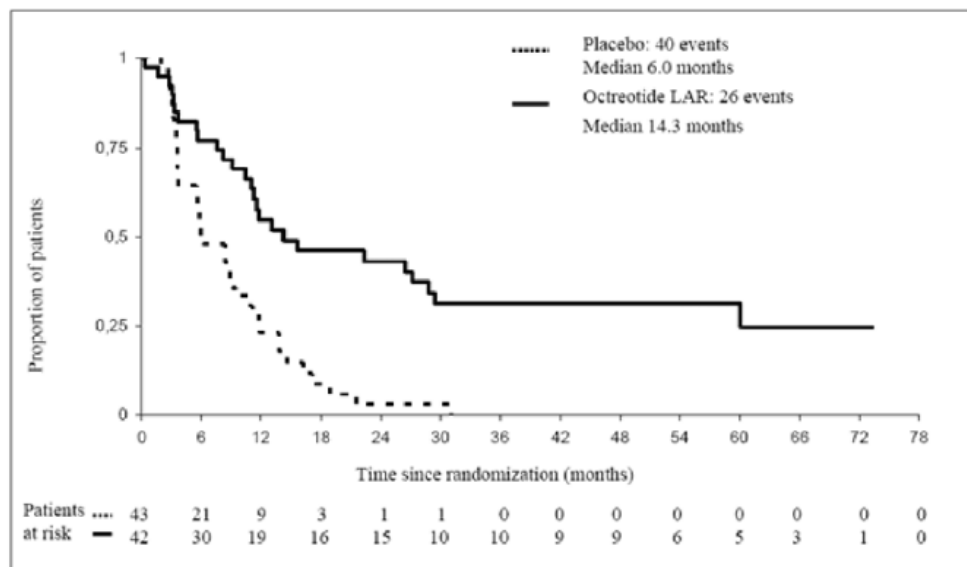

Logrank test stratified by functional activity: P=0.000072, HR= 0.34 [95%-CI: 0.20-0.59]

**Table 3 TTP results by analysis populations**

	TTP Events	Median TTP months [95% C.I.]	HR [95% C.I.]

	octreotide prolonged-release injection	Placebo	octreotide prolonged-release injection	Placebo	p-value*
ITT	26	41	NR	NR	0.32 [95% CI, 0.19 to 0.55] P=0.000015
cITT	26	40	14.3 [95% CI, 11.0 to 28.8]	6.0 [95% CI, 3.7 to 9.4]	0.34 [95% CI, 0.20 to 0.59] P=0.000072
PP	19	38	NR	NR	0.24 [95% CI, 0.13 to 0.45] P=0.000003
NR=not reported; HR=hazard ratio; TTP=time to tumour progression; ITT=intention to treat; cITT=conservative ITT; PP=per protocol *Logrank test stratified by functional activity					

Treatment effect was similar in patients with functionally active (HR = 0.23; 95% CI, 0.09 to 0.57) and inactive tumours (HR = 0.25; 95% CI, 0.10 to 0.59).

After 6 months of treatment, stable disease was observed in 67% of patients in the octreotide prolonged-release injection group and 37% of patients in the placebo group.

Based on the significant clinical benefit of octreotide prolonged-release injection observed in this pre-planned interim analysis the recruitment was stopped.

The safety of octreotide prolonged-release injection in this trial was consistent with its established safety profile.

#### Treatment of TSH-secreting pituitary adenomas

Octreotide prolonged-release injection, one i.m. injection every 4 weeks, has been shown to suppress elevated thyroid hormones, to normalise TSH and to improve the clinical signs and symptoms of hyperthyroidism in patients with TSH-secreting adenomas. Treatment effect of octreotide prolonged-release injection reached statistical significance as compared to baseline after 28 days and treatment benefit continued for up to 6 months.

## 5.2 Pharmacokinetic properties

### Absorption

After single i.m. injections of octreotide prolonged-release injection, the serum octreotide concentration reaches a transient initial peak within 1 hour after administration, followed by a progressive decrease to a low undetectable octreotide level within 24 hours. After this initial peak on day 1, octreotide remains at sub-therapeutic levels in the majority of the patients for the following 7 days. Thereafter, octreotide concentrations increase again, and

reach plateau concentrations around day 14 and remain relatively constant during the following 3 to 4 weeks. The peak level during day 1 is lower than levels during the plateau phase and no more than 0.5% of the total drug release occurs during day 1. After about day 42, the octreotide concentration decreases slowly, concomitant with the terminal degradation phase of the polymer matrix of the dosage form.

In patients with acromegaly, plateau octreotide concentrations after single doses of 10 mg, 20 mg and 30 mg octreotide prolonged-release injection amount to 358 ng/L, 926 ng/L, and 1,710 ng/L, respectively. Steady-state octreotide serum concentrations, reached after 3 injections at 4 week intervals, are higher by a factor of approximately 1.6 to 1.8 and amount to 1,557 ng/L and 2,384 ng/L after multiple injections of 20 mg and 30 mg octreotide prolonged-release injection, respectively.

In patients with carcinoid tumours, the mean (and median) steady-state serum concentrations of octreotide after multiple injections of 10 mg, 20 mg and 30 mg of octreotide prolonged-release injection given at 4 week intervals also increased linearly with dose and were 1,231 (894) ng/L, 2,620 (2,270) ng/L and 3,928 (3,010) ng/L, respectively.

No accumulation of octreotide beyond that expected from overlapping release profiles occurred over a duration of up to 28 monthly injections of octreotide prolonged-release injection.

#### Distribution and Biotransformation

The pharmacokinetic profile of octreotide after injection of octreotide prolonged-release injection reflects the release profile from the polymer matrix and its biodegradation. Once released into the systemic circulation, octreotide distributes according to its known pharmacokinetic properties, as described for s.c. administration. The volume of distribution of octreotide at steady-state is 0.27 L/kg and the total body clearance is 160 mL/min. Plasma protein binding amounts to 65% and essentially no drug is bound to blood cells.

Pharmacokinetic data with limited blood sampling in pediatric patients with hypothalamic obesity, aged 7–17 years, receiving octreotide prolonged-release injection 40 mg once monthly, showed mean octreotide trough plasma concentrations of 1,395 ng/L after the first injection and of 2,973 ng/L at steady state. A high inter-subject variability is observed.

Steady-state trough octreotide concentrations were not correlated with age and BMI, but moderately correlated with body weight (52.3–133 kg) and was significantly different between male and female patients, i.e. about 17% higher for female patients.

### **5.3 Preclinical safety data**

Acute and repeated dose toxicology, genotoxicity, carcinogenicity and reproductive toxicology studies in animals revealed no specific safety concerns for humans.

Reproduction studies in animals revealed no evidence of teratogenic, embryo/foetal or other reproduction effects due to octreotide at parental doses of up to 1 mg/kg/day. Some retardation of the physiological growth was noted in the offspring of rats which was transient and attributable to GH inhibition brought about by excessive pharmacodynamics activity (see section 4.6).

No specific studies were conducted in juvenile rats. In the pre- and post-natal developmental studies, reduced growth and maturation was observed in the F1 offspring of dams given octreotide during the entire pregnancy and lactation period. Delayed descent of the testes was observed for male F1 offsprings, but fertility of the affected F1 male pups remained normal. Thus, the above mentioned observations were transient and considered to be the consequence of GH inhibition.

## **6 PHARMACEUTICAL PARTICULARS**

### **6.1 List of excipients**

Powder (Vial):  
Poly (DL-lactide-co-glycolide)  
Mannitol (E421)

Solvent (Prefilled syringe):  
Carmellose sodium  
Mannitol (E421)  
Poloxamer  
Water for injections

### **6.2 Incompatibilities**

In the absence of compatibility studies, this medicinal product must not be mixed with other medicinal products.

### **6.3 Shelf life**

3 years  
The product must not be stored after reconstitution (must be used immediately).

#### **6.4 Special precautions for storage**

Store in the original package in order to protect from light.  
Store in a refrigerator (2°C - 8°C). Do not freeze.  
Olatuton may be stored below 25°C on the day of injection.

For storage conditions after reconstitution of the medicinal product, see section 6.3.

#### **6.5 Nature and contents of container**

Each unit contains one glass vial with rubber stopper (chlorobutyl rubber), sealed with an aluminium cap with a dark blue flip-off seal, containing powder for suspension for injection and one colourless pre-filled glass syringe with tip cap and plunger stopper (bromobutyl rubber) with 2 ml of solvent, co-packaged in a plastic tray with one vial adapter and one safety injection needle.

Packs of one and three units are available.

Not all pack sizes may be marketed.

#### **6.6 Special precautions for disposal**

Any unused medicinal product or waste material should be disposed of in accordance with local requirements.

#### **Instructions for preparation and intramuscular injection for Olatuton**

FOR DEEP INTRAMUSCULAR INJECTION ONLY

**Included in the injection kit:**

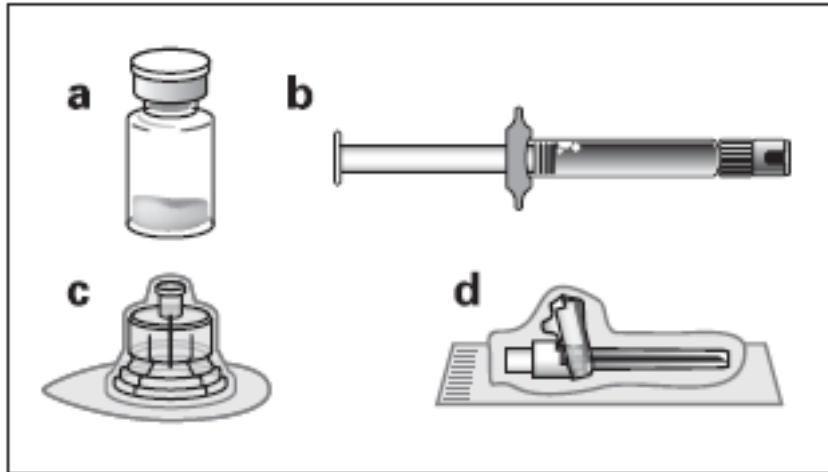

- a. One vial containing Olatuton powder
- b. One prefilled syringe containing the vehicle solution for reconstitution
- c. One vial adapter for drug product reconstitution
- d. One safety injection needle.

Follow the instructions below carefully to ensure proper reconstitution of Olatuton before deep intramuscular injection.

There are 3 critical actions in the reconstitution of Olatuton. **Not following them could result in failure to deliver the drug appropriately.**

- **The injection kit must reach room temperature.** Remove the injection kit from the fridge and let the kit stand at room temperature for a minimum of 30 minutes before reconstitution, but do not exceed 24 hours.
- After adding the diluent solution, **ensure that the powder is fully saturated** by letting the vial stand for 5 minutes.
- After saturation, **shake the vial moderately** in a horizontal direction for a minimum of 30 seconds **until a uniform suspension is formed.** The Olatuton suspension must only be prepared **immediately** before administration.

Olatuton should only be administered by a trained healthcare professional.

### Step 1

- Remove the Olatuton injection kit from refrigerated storage.

**ATTENTION: It is essential to start the reconstitution process only after the injection kit reaches room temperature. Let the kit stand at room temperature for a minimum of 30 minutes before reconstitution, but do not exceed 24 hours.**

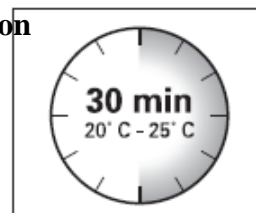

Note: The injection kit can be re-refrigerated if needed.

## Step 2

- Remove the plastic cap from the vial and clean the rubber stopper of the vial with an alcohol wipe.
- Peel the blister film and remove the vial adapter from its packaging by holding between the white luer cap and the skirt. **DO NOT** touch the tip of the access device at any place.
- Place the vial on a flat surface. Position the vial adapter on top of the vial and push it fully down so that it snaps in place, confirmed by an audible “click“.
- Clean the tip of the vial adapter with an alcohol wipe.



## Step 3

- Snap off the smooth white cap from the syringe prefilled with diluent solution and screw the syringe onto the vial adapter.
- Slowly push the plunger all the way down to transfer all the diluent solution in the vial.

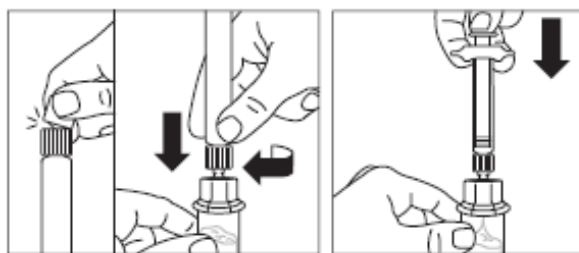

## Step 4

- ATTENTION: It is essential to let the vial stand for 5 minutes** to ensure that the diluent has fully saturated the powder.
- Note: It is normal if the plunger rod moves up as there might be a slight overpressure in the vial.
- **At this stage prepare the patient for injection**

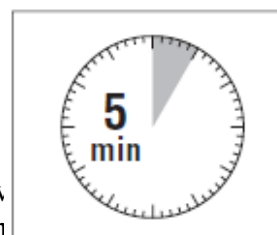

### Step 5

- After the saturation period, make sure that the plunger is pushed all the way down in the syringe.

**ATTENTION:** Keep the plunger pressed and shake the vial **moderately** in a horizontal direction **for a minimum of 30 seconds** so that the powder is completely suspended (uniform milky suspension). **Repeat moderate shaking for another 30 seconds if the powder is not completely suspended.**

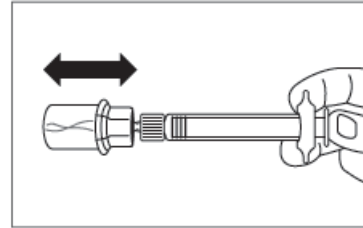

### Step 6

- Turn syringe and vial upside down, slowly pull the plunger back and draw the entire contents from the vial into the syringe.
- Unscrew the syringe from the vial adapter.

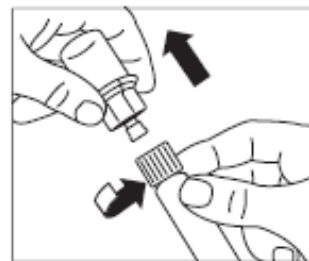
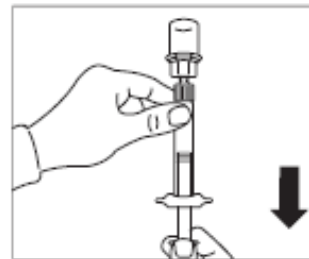

### Step 7

- Prepare the injection site with an alcohol wipe.
- Screw the safety injection needle onto the syringe.
- If immediate administration is delayed, gently **re-shake** the syringe to ensure a milky uniform suspension.
- Pull the protective cover straight off the needle.

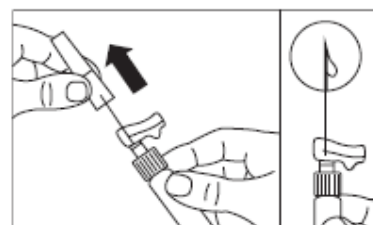
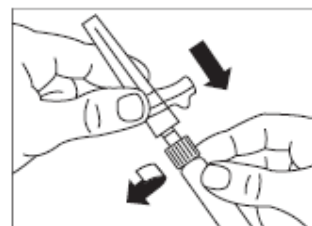

- Gently tap the syringe to remove any visible bubbles and expel them from the syringe.
- Proceed **immediately** to Step 8 for administration to the patient.  
Any delay may result in sedimentation.

### Step 8

- Olatuton must be given only by deep intramuscular injection, **NEVER** intravenously.
- Insert the needle fully into the left or right gluteus at a 90° angle to the skin.
- Slowly pull back the plunger to check that no blood vessel has been penetrated (reposition if a blood vessel has been penetrated).
- Depress the plunger with **steady pressure** until the syringe is empty. Withdraw the needle from the injection site and activate the safety guard (as shown in **Step 9**).

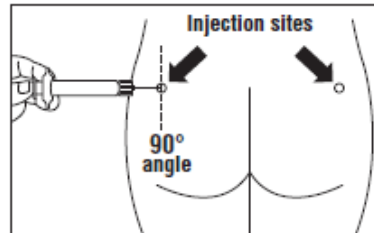

### Step 9

- Activate the safety guard over the needle in one of the 2 methods shown:
  - either press the hinged section of the safety guard down onto a hard surface (figure A)
  - or push the hinge forward with your finger (figure B).
- An audible “click” confirms the proper activation.
- Note: Record injection site on patient’s record and **alternate monthly**
- Dispose of syringe immediately (in a sharps container).

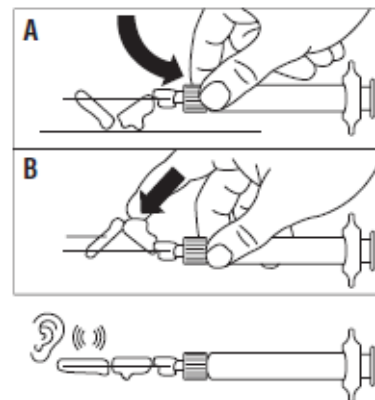

## 7 MARKETING AUTHORISATION HOLDER

Teva UK Limited,  
Ridings Point,  
Whistler Drive,  
Castleford,

WF10 5HX,  
United Kingdom

**8      MARKETING AUTHORISATION NUMBER(S)**

PL 00289/2219

**9      DATE OF FIRST AUTHORISATION/RENEWAL OF THE  
AUTHORISATION**

21/02/2024

**10     DATE OF REVISION OF THE TEXT**

21/02/2024