

# SUMMARY OF PRODUCT CHARACTERISTICS

## 1 NAME OF THE MEDICINAL PRODUCT

Enalapril Maleate 5mg/5ml Oral Solution

## 2 QUALITATIVE AND QUANTITATIVE COMPOSITION

Each 5 ml contains 5 mg enalapril maleate.

Excipients with known effect:

Sodium Benzoate (E211) 4.70 mg/5 ml

For a full list of excipients, see section 6.1.

## 3 PHARMACEUTICAL FORM

Oral solution

Clear colourless solution

## 4 CLINICAL PARTICULARS

### 4.1 Therapeutic indications

- Treatment of Hypertension
- Treatment of Symptomatic Heart Failure
- Prevention of Symptomatic Heart Failure in patients with Asymptomatic Left Ventricular Dysfunction (ejection fraction  $\leq 35$  %) (See section 5.1)

### 4.2 Posology and method of administration

Posology

The dose should be individualised according to patient profile (see section 4.4) and blood pressure response.

*Paediatric Population*

There is limited clinical trial experience of the use of enalapril in hypertensive paediatric patients (see sections 4.4, 5.1 and 5.2).

*Hypertension*

The initial dose is 5 mg (5 ml) to maximally 20 mg (20 ml), depending on the degree of hypertension and the condition of the patient (see below). Enalapril is given once daily. In mild hypertension, the recommended initial dose is 5 mg to 10 mg (5 ml to 10 ml). Patients with a strongly activated renin-angiotensin-aldosterone system (e.g., renovascular hypertension, salt and/or volume depletion, cardiac decompensation, or severe hypertension) may experience an excessive blood pressure fall following the initial dose. A starting dose of 5 mg (5 ml) or lower is recommended in such patients and the initiation of treatment should take place under medical supervision.

Prior treatment with high dose diuretics may result in volume depletion and a risk of hypotension when initiating therapy with enalapril. A starting dose of 5 mg (5 ml) or lower is recommended in such patients. If possible, diuretic therapy should be discontinued for 2-3 days prior to initiation of therapy with enalapril. Renal function and serum potassium should be monitored.

The usual maintenance dose is 20 mg (20 ml) daily. The maximum maintenance dose is 40 mg (40 ml) daily.

*Heart Failure/Asymptomatic Left Ventricular Dysfunction*

In the management of symptomatic heart failure, enalapril is used in addition to diuretics and, where appropriate, digitalis or beta-blockers. The initial dose of enalapril in patients with symptomatic heart failure or asymptomatic left ventricular dysfunction is 2.5 mg (2.5 ml), and it should be administered under close medical supervision to determine the initial effect on the blood pressure. In the absence of, or after effective management of, symptomatic hypotension following initiation of therapy with enalapril in heart failure, the dose should be increased gradually to the usual maintenance dose of 20 mg (20 ml), given in a single dose or two divided doses, as tolerated by the patient. This dose titration is recommended to be performed over a 2 to 4 week period. The maximum dose is 40 mg (40 ml) daily given in two divided doses.

Table 1: Suggested Dosage Titration of Enalapril in Patients with Heart Failure/Asymptomatic Left Ventricular Dysfunction

<b>Week</b>	<b>Dose mg/day (ml/day)</b>
Week 1	<b>Days 1 to 3:</b> 2.5 mg/day* (2.5 ml/day*) in a single dose <b>Days 4 to 7:</b> 5 mg/day (5 ml/day) in two divided doses
Week 2	10 mg/day (10 ml/day) in a single dose or in two divided doses
Weeks 3 and 4	20 mg/day (20 ml/day) in a single dose or in two divided doses

\* Special precautions should be followed in patients with impaired renal function or taking diuretics (see section 4.4).

Blood pressure and renal function should be monitored closely both before and after starting treatment with enalapril (see section 4.4) because hypotension and (more rarely) consequent renal failure have been reported. In patients treated with diuretics, the dose should be reduced if possible before beginning treatment with enalapril. The appearance of hypotension after the initial dose of enalapril does not imply that hypotension will recur during chronic therapy with enalapril and does not preclude continued use of the drug. Serum potassium and renal function also should be monitored.

### *Dosage in Renal Insufficiency*

Generally, the intervals between the administration of enalapril should be prolonged and/or the dosage reduced.

Table 2: Dosage in Renal Insufficiency

<b>Creatinine Clearance (CrCL) ml/min</b>	<b>Initial Dose mg/day</b>
30 < CrCL < 80 ml/min.	5 - 10 mg (5 – 10 ml)
10 < CrCL ≤ 30 ml/min.	2.5 mg (2.5 ml)
CrCL ≤ 10 ml/min.	2.5 mg (2.5 ml) on dialysis days*

\*See section 4.4. Enalaprilat is dialysable. Dosage on nondialysis days should be adjusted depending on the blood pressure response.

### *Use in Elderly*

The dose should be in line with the renal function of the elderly patient (see section 4.4).

### *Use in Paediatrics*

The dose should be individualised according to patient profile and blood pressure response. The recommended initial dose is 2.5 mg (2.5 ml) in patients 20 to < 50 kg and 5 mg (5 ml) in patients ≥ 50 kg. Enalapril is given once daily. The dosage should be adjusted according to the needs of the patient to a maximum of 20 mg (20 ml) daily in patients 20 to < 50 kg and 40 mg (40 ml) in patients ≥ 50 kg (see section 4.4).

Enalapril is not recommended in neonates and in paediatric patients with glomerular filtration rate < 30 ml/min/1.73 m<sup>2</sup>, as no data are available.

### Method of administration

For oral use.

Enalapril can be taken with or without food.

Take Enalapril Oral Solution with a glass of water.

An oral dosing device is provided with the pack. For instructions on how to use the device, refer to section 6.6.

Where higher doses are to be administered, dosing cups should be considered. These can be provided by your pharmacist.

## **4.3 Contraindications**

- Hypersensitivity to the active substance or to any of the excipients listed in section 6.1 or any other ACE inhibitor.
- History of angioedema associated with previous ACE inhibitor therapy.
- Hereditary or idiopathic angioedema.
- The concomitant use of enalapril with aliskiren-containing products is contraindicated in patients with diabetes mellitus or renal impairment (GFR < 60 ml/min/1.73 m<sup>2</sup>) (see sections 4.5 and 5.1).

- Second and third trimesters of pregnancy (see sections 4.4 and 4.6).
- Concomitant use with sacubitril/valsartan therapy. Enalapril must not be initiated earlier than 36 hours after the last dose of sacubitril/valsartan (see also sections 4.4 and 4.5).

#### **4.4 Special warnings and precautions for use**

##### Symptomatic Hypotension

Symptomatic hypotension is rarely seen in uncomplicated hypertensive patients. In hypertensive patients receiving enalapril, symptomatic hypotension is more likely to occur if the patient has been volume depleted, e.g., by diuretic therapy, dietary salt restriction, dialysis, diarrhoea or vomiting (see sections 4.5 and 4.8). In patients with heart failure, with or without associated renal insufficiency, symptomatic hypotension has been observed. This is most likely to occur in those patients with more severe degrees of heart failure, as reflected by the use of high doses of loop diuretics, hyponatraemia or functional renal impairment. In these patients, therapy should be started under medical supervision and the patients should be followed closely whenever the dose of enalapril and/or diuretic is adjusted. Similar considerations may apply to patients with ischaemic heart or cerebrovascular disease in whom an excessive fall in blood pressure could result in a myocardial infarction or cerebrovascular accident.

If hypotension occurs, the patient should be placed in the supine position and, if necessary, should receive an intravenous infusion of normal saline. A transient hypotensive response is not a contraindication to further doses, which can be given usually without difficulty once the blood pressure has increased after volume expansion.

In some patients with heart failure who have normal or low blood pressure, additional lowering of systemic blood pressure may occur with enalapril. This effect is anticipated, and usually is not a reason to discontinue treatment. If hypotension becomes symptomatic, a reduction of dose and/or discontinuation of the diuretic and/or enalapril may be necessary.

##### Aortic or Mitral Valve Stenosis/Hypertrophic Cardiomyopathy

As with all vasodilators, ACE inhibitors should be given with caution in patients with left ventricular valvular and outflow tract obstruction and avoided in cases of cardiogenic shock and haemodynamically significant obstruction.

##### Renal Function Impairment

In cases of renal impairment (creatinine clearance < 80 ml/min) the initial enalapril dosage should be adjusted according to the patient's creatinine clearance (see section 4.2) and then as a function of the patient's response to treatment. Routine monitoring of potassium and creatinine are part of normal medical practice for these patients.

Renal failure has been reported in association with enalapril and has been mainly in patients with severe heart failure or underlying renal disease, including renal artery stenosis. If recognised promptly and treated appropriately, renal failure when associated with therapy with enalapril is usually reversible.

Some hypertensive patients, with no apparent pre-existing renal disease have developed increases in blood urea and creatinine when enalapril has been given concurrently with a diuretic. Dosage reduction of enalapril and/or discontinuation of

the diuretic may be required. This situation should raise the possibility of underlying renal artery stenosis (see section 4.4, Renovascular hypertension).

#### Renovascular hypertension

There is an increased risk of hypotension and renal insufficiency when patients with bilateral renal artery stenosis or stenosis of the artery to a single functioning kidney are treated with ACE inhibitors. Loss of renal function may occur with only mild changes in serum creatinine. In these patients, therapy should be initiated under close medical supervision with low doses, careful titration, and monitoring of renal function.

#### Kidney Transplantation

There is no experience regarding the administration of enalapril in patients with a recent kidney transplantation. Treatment with enalapril is therefore not recommended.

#### Hepatic failure

Rarely, ACE inhibitors have been associated with a syndrome that starts with cholestatic jaundice or hepatitis and progresses to fulminant hepatic necrosis and (sometimes) death. The mechanism of this syndrome is not understood. Patients receiving ACE inhibitors who develop jaundice or marked elevations of hepatic enzymes should discontinue the ACE inhibitor and receive appropriate medical follow-up.

#### Neutropenia/Agranulocytosis

Neutropenia/agranulocytosis, thrombocytopenia and anaemia have been reported in patients receiving ACE inhibitors. In patients with normal renal function and no other complicating factors, neutropenia occurs rarely. Enalapril should be used with extreme caution in patients with collagen vascular disease, immunosuppressant therapy, treatment with allopurinol or procainamide, or a combination of these complicating factors, especially if there is pre-existing impaired renal function. Some of these patients developed serious infections which in a few instances did not respond to intensive antibiotic therapy. If enalapril is used in such patients, periodic monitoring of white blood cell counts is advised and patients should be instructed to report any sign of infection.

#### Hypersensitivity/Angioneurotic Oedema

Angioneurotic oedema of the face, extremities, lips, tongue, glottis and/or larynx has been reported in patients treated with angiotensin converting enzyme inhibitors, including enalapril. This may occur at any time during treatment. In such cases, enalapril should be discontinued promptly and appropriate monitoring should be instituted to ensure complete resolution of symptoms prior to dismissing the patient. Even in those instances where swelling of only the tongue is involved, without respiratory distress, patients may require prolonged observation since treatment with antihistamines and corticosteroids may not be sufficient.

Very rarely, fatalities have been reported due to angioedema associated with laryngeal oedema or tongue oedema. Patients with involvement of the tongue, glottis or larynx are likely to experience airway obstruction, especially those with a history of airway surgery. Where there is involvement of the tongue, glottis or larynx, likely to cause airway obstruction, appropriate therapy, which may include subcutaneous epinephrine solution 1:1000 (0.3 ml to 0.5 ml) and/or measures to ensure a patent airway, should be administered promptly.

Black patients receiving ACE inhibitors have been reported to have a higher incidence of angioedema compared to non-blacks.

Patients with a history of angioedema unrelated to ACE inhibitor therapy may be at increased risk of angioedema while receiving an ACE inhibitor (see section 4.3).

Concomitant use of ACE inhibitors with sacubitril/valsartan is contraindicated due to the increased risk of angioedema. Treatment with sacubitril/valsartan must not be initiated earlier than 36 hours after the last dose of enalapril. Treatment with enalapril must not be initiated earlier than 36 hours after the last dose of sacubitril/valsartan (see sections 4.3 and 4.5).

Concomitant use of ACE inhibitors with racecadotril, mTOR inhibitors (e.g., sirolimus, everolimus, temsirolimus) and vildagliptin may lead to an increased risk of angioedema (e.g. swelling of the airways or tongue, with or without respiratory impairment) (see section 4.5). Caution should be used when starting racecadotril, mTOR inhibitors (e.g. sirolimus, everolimus, temsirolimus) and vildagliptin in a patient already taking an ACE inhibitor.

#### Anaphylactoid Reactions during Hymenoptera Desensitisation

Rarely, patients receiving ACE inhibitors during desensitisation with hymenoptera venom have experienced life-threatening anaphylactoid reactions. These reactions were avoided by temporarily withholding ACE inhibitor therapy prior to each desensitisation.

#### Anaphylactoid Reactions during LDL Apheresis

Rarely, patients receiving ACE inhibitors during low density lipoprotein (LDL)-apheresis with dextran sulfate have experienced life-threatening anaphylactoid reactions. These reactions were avoided by temporarily withholding ACE inhibitor therapy prior to each apheresis.

#### Haemodialysis Patients

Anaphylactoid reactions have been reported in patients dialysed with high-flux membranes (e.g., AN 69) and treated concomitantly with an ACE inhibitor. In these patients consideration should be given to using a different type of dialysis membrane or a different class of antihypertensive agent.

#### Hypoglycaemia

Diabetic patients treated with oral antidiabetic agents or insulin starting an ACE inhibitor should be told to closely monitor for hypoglycaemia, especially during the first month of combined use (see section 4.5).

#### Cough

Cough has been reported with the use of ACE inhibitors. Characteristically, the cough is non-productive, persistent, and resolves after discontinuation of therapy. ACE inhibitor-induced cough should be considered as part of the differential diagnosis of cough.

#### Surgery/Anaesthesia

In patients undergoing major surgery or during anaesthesia with agents that produce hypotension, enalapril blocks angiotensin II formation secondary to compensatory renin release. If hypotension occurs and is considered to be due to this mechanism, it can be corrected by volume expansion.

#### Hyperkalaemia

ACE inhibitors can cause hyperkalaemia because they inhibit the release of aldosterone. The effect is usually not significant in patients with normal renal

function. However, in patients with impaired renal function and/or in patients taking potassium supplements (including salt substitutes), potassium-sparing diuretics, trimethoprim or co-trimoxazole also known as trimethoprim/sulfamethoxazole and especially aldosterone antagonists or angiotensin receptor blockers, hyperkalaemia can occur. Potassium-sparing diuretics and angiotensin receptor blockers should be used with caution in patients receiving ACE inhibitors, and serum potassium and renal function should be monitored (see section 4.5).

#### Lithium

The combination of lithium and enalapril is generally not recommended (see section 4.5).

#### Dual blockade of the renin-angiotensin-aldosterone system (RAAS)

There is evidence that the concomitant use of ACE inhibitors, angiotensin II receptor blockers or aliskiren increases the risk of hypotension, hyperkalaemia, and decreased renal function (including acute renal failure). Dual blockade of RAAS through the combined use of ACE inhibitors, angiotensin II receptor blockers or aliskiren is therefore not recommended (see sections 4.5 and 5.1).

If dual blockade therapy is considered absolutely necessary, this should only occur under specialist supervision and subject to frequent close monitoring of renal function, electrolytes and blood pressure.

ACE-inhibitors and angiotensin II receptor blockers should not be used concomitantly in patients with diabetic nephropathy.

#### Paediatric population

There is limited efficacy and safety experience in hypertensive children > 6 years old, but no experience in other indications. Limited pharmacokinetic data are available in children above 2 months of age (see sections 4.2, 5.1 and 5.2). Enalapril is not recommended in children in other indications than hypertension.

Enalapril is not recommended in neonates and in paediatric patients with glomerular filtration rate < 30 mL/min/1.73 m<sup>2</sup>, as no data are available (see section 4.2).

#### Pregnancy

ACE inhibitors should not be initiated during pregnancy. Unless continued ACE inhibitor therapy is considered essential, patients planning pregnancy should be changed to alternative antihypertensive treatments which have an established safety profile for use in pregnancy. When pregnancy is diagnosed, treatment with ACE inhibitors should be stopped immediately, and, if appropriate, alternative therapy should be started (see sections 4.3 and 4.6).

#### Ethnic differences

As with other angiotensin converting enzyme inhibitors, enalapril is apparently less effective in lowering blood pressure in black people than in non-blacks, possibly because of a higher prevalence of low-renin states in the black hypertensive population.

#### Excipient Warnings

This medicinal product contains less than 1 mmol sodium (23 mg) per 5ml, that is to say essentially 'sodium free'.

This medicine contains 4.70 mg sodium benzoate (E211) in each 5ml.

## 4.5 Interaction with other medicinal products and other forms of interaction

### Medicines increasing the risk of angioedema

Concomitant use of ACE inhibitors with sacubitril/valsartan is contraindicated as this increases the risk of angioedema (see sections 4.3 and 4.4).

Concomitant use of ACE inhibitors with racecadotril, mTOR inhibitors (e.g. sirolimus, everolimus, temsirolimus) and vildagliptin may lead to an increased risk for angioedema (see section 4.4).

### Dual blockade of the renin-angiotensin-aldosterone system (RAAS)

Clinical trial data have shown that dual blockade of the renin-angiotensin-aldosterone-system (RAAS) through the combined use of ACE inhibitors, angiotensin II receptor blockers or aliskiren is associated with a higher frequency of adverse events such as hypotension, hyperkalaemia and decreased renal function (including acute renal failure) compared to the use of a single RAAS-acting agent (see sections 4.3, 4.4 and 5.1).

### Potassium sparing diuretics, potassium supplements, or other drugs that may increase serum potassium

Although serum potassium usually remains within normal limits, hyperkalaemia may occur in some patients treated with enalapril. Potassium-sparing diuretics (e.g. spironolactone, triamterene, or amiloride), potassium supplements, or potassium-containing salt substitutes may lead to significant increases in serum potassium. Care should also be taken when enalapril is co-administered with other agents that increase serum potassium, such as trimethoprim and cotrimoxazole (trimethoprim/sulfamethoxazole) as trimethoprim is known to act as a potassium-sparing diuretic like amiloride. Therefore, the combination of enalapril with the above-mentioned drugs is not recommended. If concomitant use is indicated, they should be used with caution and with frequent monitoring of serum potassium.

### Ciclosporin

Hyperkalaemia may occur during concomitant use of ACE inhibitors with ciclosporin. Monitoring of serum potassium is recommended.

### Heparin

Hyperkalaemia may occur during concomitant use of ACE inhibitors with heparin. Monitoring of serum potassium is recommended.

### Diuretics (thiazide or loop diuretics)

Prior treatment with high dose diuretics may result in volume depletion and a risk of hypotension when initiating therapy with enalapril (see section 4.4). The hypotensive effects can be reduced by discontinuation of the diuretic, by increasing volume or salt intake or by initiating therapy with a low dose of enalapril.

### Other antihypertensive agents

Concomitant use of these agents may increase the hypotensive effects of enalapril. Concomitant use with nitroglycerine and other nitrates, or other vasodilators, may further reduce blood pressure.

### Lithium

Reversible increases in serum lithium concentrations and toxicity have been reported during concomitant administration of lithium with ACE inhibitors. Concomitant use of thiazide diuretics may further increase lithium levels and enhance the risk of lithium toxicity with ACE inhibitors. Use of enalapril with lithium is not



recommended, but if the combination proves necessary, careful monitoring of serum lithium levels should be performed (see section 4.4).

#### Tricyclic antidepressants/Antipsychotics/Anaesthetics/Narcotics

Concomitant use of certain anaesthetic medicinal products, tricyclic antidepressants and antipsychotics with ACE inhibitors may result in further reduction of blood pressure (see section 4.4).

#### Non-Steroidal Anti-Inflammatory Drugs (NSAIDs) Including Selective Cyclooxygenase-2 (COX-2) Inhibitors

Non-steroidal anti-inflammatory drugs (NSAIDs) including selective cyclooxygenase-2 inhibitors (COX-2 inhibitors) may reduce the effect of diuretics and other antihypertensive drugs. Therefore, the antihypertensive effect of angiotensin II receptor antagonists or ACE inhibitors may be attenuated by NSAIDs including selective COX-2 inhibitors.

The co-administration of NSAIDs (including COX-2 inhibitors) and angiotensin II receptor antagonists or ACE inhibitors exert an additive effect on the increase in serum potassium and may result in a deterioration of renal function. These effects are usually reversible. Rarely, acute renal failure may occur, especially in patients with compromised renal function (such as the elderly or patients who are volume-depleted, including those on diuretic therapy). Therefore, the combination should be administered with caution in patients with compromised renal function. Patients should be adequately hydrated and consideration should be given to monitoring renal function after initiation of concomitant therapy and periodically thereafter.

#### Gold

Nitritoid reactions (symptoms include facial flushing, nausea, vomiting and hypotension) have been reported rarely in patients on therapy with injectable gold (sodium aurothiomalate) and concomitant ACE inhibitor therapy including enalapril.

#### Sympathomimetics

Sympathomimetics may reduce the antihypertensive effects of ACE inhibitors.

#### Antidiabetics

Epidemiological studies have suggested that concomitant administration of ACE inhibitors and antidiabetic medicines (insulins, oral hypoglycaemic agents) may cause an increased blood-glucose-lowering effect with risk of hypoglycaemia. This phenomenon appeared to be more likely to occur during the first weeks of combined treatment and in patients with renal impairment (see sections 4.4 and 4.8).

#### Alcohol

Alcohol enhances the hypotensive effect of ACE inhibitors.

#### Acetyl salicylic acid, thrombolytics and $\beta$ -blockers

Enalapril can be safely administered concomitantly with acetyl salicylic acid (at cardiologic doses), thrombolytics and  $\beta$ -blockers.

#### Paediatric population

Interaction studies have only been performed in adults.

## 4.6 Fertility, pregnancy and lactation

### Pregnancy

ACE inhibitors:

The use of ACE inhibitors is not recommended during the first trimester of pregnancy (see section 4.4). The use of ACE inhibitors is contra-indicated during the second and third trimesters of pregnancy (see sections 4.3 and 4.4).

Epidemiological evidence regarding the risk of teratogenicity following exposure to ACE inhibitors during the first trimester of pregnancy has not been conclusive; however, a small increase in risk cannot be excluded. Unless continued ACE inhibitor therapy is considered essential, patients planning pregnancy should be changed to alternative anti-hypertensive treatments which have an established safety profile for use in pregnancy.

When pregnancy is diagnosed, treatment with ACE inhibitors should be stopped immediately, and, if appropriate, alternative therapy should be started.

Exposure to ACE inhibitor therapy during the second and third trimesters is known to induce human foetotoxicity (decreased renal function, oligohydramnios, skull ossification retardation) and neonatal toxicity (renal failure, hypotension, hyperkalaemia) (see section 5.3). Maternal oligohydramnios, presumably representing decreased foetal renal function, has occurred and may result in limb contractures, craniofacial deformations and hypoplastic lung development.

Should exposure to ACE inhibitors have occurred from the second trimester of pregnancy, ultrasound check of renal function and skull is recommended.

Infants whose mothers have taken ACE inhibitors should be closely observed for hypotension (see sections 4.3 and 4.4).

### Breast-feeding

Limited pharmacokinetic data demonstrate very low concentrations in breast milk (see section 5.2). Although these concentrations seem to be clinically irrelevant, the use of enalapril in breast-feeding is not recommended for preterm infants and for the first few weeks after delivery, because of the hypothetical risk of cardiovascular and renal effects and because there is not enough clinical experience. In case of an older infant, the use of enalapril in breast-feeding mother may be considered if this treatment is necessary for the mother and the child is observed for any adverse effect.

## 4.7 Effects on ability to drive and use machines

When driving vehicles or operating machines it should be taken into account that occasionally dizziness or weariness may occur.

## 4.8 Undesirable effects

The following undesirable effects have been reported for enalapril in clinical studies and in post-marketing experience:

**Table 3. Undesirable effects of enalapril**

<b>System organ class</b>	<b>Very common (≥1/10)</b>	<b>Common (≥1/100 to &lt;1/10)</b>	<b>Uncommon (≥1/1,000 to &lt;1/100)</b>	<b>Rare (≥1/10,000 to &lt;1/1,000)</b>	<b>Very rare (&lt;1/10,000)</b>	<b>Not known (cannot be estimated from the available data)</b>
<i>Blood and lymphatic system disorders</i>			Anaemia (including aplastic and haemolytic)	Neutropenia, decreases in haemoglobin, decreases in haematocrit, thrombocytopenia, agranulocytosis, bone marrow depression, pancytopenia, lymphadenopathy, autoimmune diseases		
<i>Endocrine disorders</i>						Syndrome of inappropriate antidiuretic hormone secretion (SIADH)
<i>Metabolism and nutrition disorders</i>			Hypoglycaemia (see section 4.4)			
<i>Psychiatric disorders</i>		Depression	Confusion, nervousness, insomnia	Dream abnormality, sleep disorders		
<i>Nervous system disorders</i>	Dizziness	Headache, syncope, taste alteration	Somnolence, paresthesia, vertigo			
<i>Eye disorders</i>	Blurred vision					
<i>Ear and labyrinth disorders</i>			Tinnitus			
<i>Cardiac disorders</i>		Chest pain, rhythm disturbances, angina pectoris, tachycardia	Palpitations, myocardial infarction or cerebrovascular accident*, possibly secondary to excessive hypotension in high risk patients (see section 4.4)			
<i>Vascular disorders</i>		Hypotension (including orthostatic hypotension)	Flushing, orthostatic hypotension	Raynaud's phenomenon		
<i>Respiratory, thoracic, and mediastinal disorders</i>	Cough	Dyspnoea	Rhinorrhoea, sore throat and hoarseness, bronchospasm/asthma	Pulmonary infiltrates, rhinitis, allergic alveolitis/eosinophilia pneumonia		

<b><i>Gastrointestinal disorders</i></b>	Nausea	Diarrhoea, abdominal pain	Ileus, pancreatitis, vomiting, dyspepsia, constipation, anorexia, gastric irritations, dry mouth, peptic ulcer	Stomatitis/aphthous ulcerations, glossitis	Intestinal angioedema	
<b><i>Hepatobiliary disorders</i></b>				Hepatic failure, hepatitis – either hepatocellular or cholestatic, hepatitis including necrosis, cholestasis (including jaundice)		
<b><i>Skin and subcutaneous tissue disorders</i></b>		Rash, hypersensitivity/ angioneurotic oedema: angioneurotic oedema of the face, extremities, lips, tongue, glottis and/or larynx has been reported (see section 4.4)	Diaphoresis, pruritus, urticaria, alopecia	Erythema multiforme, Stevens-Johnson syndrome, exfoliative dermatitis, toxic epidermal necrolysis, pemphigus, erythroderma		A symptom complex has been reported which may include some or all of the following: fever, serositis, vasculitis, myalgia/myositis, arthralgia/arthritis, a positive ANA, elevated ESR, eosinophilia, and leucocytosis. Rash, photosensitivity or other dermatologic manifestations may occur.
<b><i>Musculoskeletal, connective tissue, and bone disorders</i></b>			Muscle cramps			
<b><i>Renal and urinary disorders</i></b>			Renal dysfunction, renal failure, proteinuria	Oliguria		
<b><i>Reproductive system and breast disorders</i></b>			Impotence	Gynaecomastia		
<b><i>General disorders and administration site conditions</i></b>	Asthenia	Fatigue	Malaise, fever			
<b><i>Investigations</i></b>		Hyperkalaemia, increases in serum creatinine	Increases in blood urea, hyponatraemia	Elevations of liver enzymes, elevations of serum bilirubin		

\* Incidence rates were comparable to those in the placebo and active control groups in the clinical trials

#### Reporting of suspected adverse reactions

Reporting suspected adverse reactions after authorisation of the medicinal product is important. It allows continued monitoring of the benefit/risk balance of the medicinal product. Healthcare professionals are asked to report any suspected adverse reactions via the Yellow Card Scheme. Website: [www.mhra.gov.uk/yellowcard](http://www.mhra.gov.uk/yellowcard) or search for MHRA Yellow Card in the Google Play or Apple App Store.

## **4.9 Overdose**

Limited data are available for overdosage in humans. The most prominent features of overdosage reported to date are marked hypotension, beginning some six hours after ingestion of enalapril, concomitant with blockade of the renin-angiotensin system, and stupor. Symptoms associated with overdosage of ACE inhibitors may include circulatory shock, electrolyte disturbances, renal failure, hyperventilation, tachycardia, palpitations, bradycardia, dizziness, anxiety, and cough. Serum enalaprilat levels 100- and 200-fold higher than usually seen after therapeutic doses have been reported after ingestion of 300 mg and 440 mg of enalapril, respectively.

The recommended treatment of overdosage is intravenous infusion of normal saline solution. If hypotension occurs, the patient should be placed in the shock position. If available, treatment with angiotensin II infusion and/or intravenous catecholamines may also be considered. If ingestion is recent, take measures aimed at eliminating enalapril (e.g., emesis, gastric lavage, administration of absorbents, and sodium sulfate). Enalaprilat may be removed from the general circulation by haemodialysis (see section 4.4). Pacemaker therapy is indicated for therapy-resistant bradycardia. Vital signs, serum electrolytes and creatinine concentrations should be monitored continuously.

## **5 PHARMACOLOGICAL PROPERTIES**

### **5.1 Pharmacodynamic properties**

Pharmacotherapeutic group: Angiotensin converting enzyme inhibitors,  
ATC Code: C09A A02

Enalapril maleate is the maleate salt of enalapril, a derivative of two amino-acids, L-alanine and L-proline. Angiotensin converting enzyme (ACE) is a peptidyl dipeptidase which catalyses the conversion of angiotensin I to the pressor substance angiotensin II. After absorption, enalapril is hydrolysed to enalaprilat, which inhibits ACE. Inhibition of ACE results in decreased plasma angiotensin II, which leads to increased plasma renin activity (due to removal of negative feedback of renin release), and decreased aldosterone secretion.

ACE is identical to kininase II. Thus, enalapril may also block the degradation of bradykinin, a potent vasodepressor peptide. However, the role that this plays in the therapeutic effects of enalapril remains to be elucidated.

### Mechanism of action

While the mechanism through which enalapril lowers blood pressure is believed to be primarily suppression of the renin-angiotensin-aldosterone system, enalapril is antihypertensive even in patients with low-renin hypertension.

### Pharmacodynamic effects

Administration of enalapril to patients with hypertension results in a reduction of both supine and standing blood pressure without a significant increase in heart rate.

Symptomatic postural hypotension is infrequent. In some patients the development of optimal blood pressure reduction may require several weeks of therapy. Abrupt withdrawal of enalapril has not been associated with rapid increase in blood pressure.

Effective inhibition of ACE activity usually occurs 2 to 4 hours after oral administration of an individual dose of enalapril. Onset of antihypertensive activity was usually seen at one hour, with peak reduction of blood pressure achieved by 4 to 6 hours after administration. The duration of effect is dose-related. However, at recommended doses, antihypertensive and haemodynamic effects have been shown to be maintained for at least 24 hours.

In haemodynamic studies in patients with essential hypertension, blood pressure reduction was accompanied by a reduction in peripheral arterial resistance with an increase in cardiac output and little or no change in heart rate. Following administration of enalapril there was an increase in renal blood flow; glomerular filtration rate was unchanged. There was no evidence of sodium or water retention. However, in patients with low pre-treatment glomerular filtration rates, the rates were usually increased.

In short term clinical studies in diabetic and nondiabetic patients with renal disease, decreases in albuminuria and urinary excretion of IgG and total urinary protein were seen after the administration of enalapril.

When given together with thiazide-type diuretics, the blood pressure-lowering effects of enalapril are at least additive. Enalapril may reduce or prevent the development of thiazide-induced hypokalaemia.

In patients with heart failure on therapy with digitalis and diuretics, treatment with oral or injection Enalapril was associated with decreases in peripheral resistance and blood pressure. Cardiac output increased, while heart rate (usually elevated in patients with heart failure) decreased. Pulmonary capillary wedge pressure was also reduced. Exercise tolerance and severity of heart failure, as measured by New York Heart Association criteria, improved. These actions continued during chronic therapy.

In patients with mild to moderate heart failure, enalapril retarded progressive cardiac dilatation/enlargement and failure, as evidenced by reduced left ventricular end diastolic and systolic volumes and improved ejection fraction.

### Dual Blockade of the renin-angiotensin-aldosterone system (RAAS)

Two large randomised, controlled trials (ONTARGET (ONgoing Telmisartan Alone and in combination with Ramipril Global Endpoint Trial) and VA NEPHRON-D (The Veterans Affairs Nephropathy in Diabetes)) have examined the use of the combination of an ACE-inhibitor with an angiotensin II receptor blocker.

ONTARGET was a study conducted in patients with a history of cardiovascular or cerebrovascular disease, or type 2 diabetes mellitus accompanied by evidence of end-

organ damage. VA NEPHRON-D was a study in patients with type 2 diabetes mellitus and diabetic nephropathy.

These studies have shown no significant beneficial effect on renal and/or cardiovascular outcomes and mortality, while an increased risk of hyperkalaemia, acute kidney injury and/or hypotension as compared to monotherapy was observed. Given their similar pharmacodynamic properties, these results are also relevant for other ACE-inhibitors and angiotensin II receptor blockers.

ACE-inhibitors and angiotensin II receptor blockers should therefore not be used concomitantly in patients with diabetic nephropathy.

ALTITUDE (Aliskiren Trial in Type 2 Diabetes Using Cardiovascular and Renal Disease Endpoints) was a study designed to test the benefit of adding aliskiren to a standard therapy of an ACE-inhibitor or an angiotensin II receptor blocker in patients with type 2 diabetes mellitus and chronic kidney disease, cardiovascular disease, or both. The study was terminated early because of an increased risk of adverse outcomes. Cardiovascular death and stroke were both numerically more frequent in the aliskiren group than in the placebo group and adverse events and serious adverse events of interest (hyperkalaemia, hypotension and renal dysfunction) were more frequently reported in the aliskiren group than in the placebo group.

#### Clinical efficacy and safety

A multicentre, randomised, double-blind, placebo-controlled trial (SOLVD Prevention trial) examined a population with asymptomatic left ventricular dysfunction (LVEF < 35 %). 4,228 patients were randomised to receive either placebo (n = 2,117) or enalapril (n = 2,111). In the placebo group, 818 patients had heart failure or died (38.6 %) as compared with 630 in the enalapril group (29.8 %) (risk reduction: 29 %; 95 % CI; 21- 36 %; p < 0.001). 518 patients in the placebo group (24.5 %) and 434 in the enalapril group (20.6 %) died or were hospitalised for new or worsening heart failure (risk reduction 20 %; 95% CI; 9 - 30 %; p < 0.001).

A multicentre, randomised, double-blind, placebo-controlled trial (SOLVD Treatment trial) examined a population with symptomatic congestive heart failure due to systolic dysfunction (ejection fraction <35 %). 2,569 patients receiving conventional treatment for heart failure were randomly assigned to receive either placebo (n = 1,284) or enalapril (n=1,285). There were 510 deaths in the placebo group (39.7 %) as compared with 452 in the enalapril group (35.2 %) (reduction in risk, 16 %; 95 % CI, 5 - 26 %; p=0.0036). There were 461 cardiovascular deaths in the placebo group as compared with 399 in the enalapril group (risk reduction 18%, 95% CI, 6 - 28 %, p < 0.002), mainly due to a decrease of deaths due to progressive heart failure (251 in the placebo group vs 209 in the enalapril group, risk reduction 22 %, 95 % CI, 6-35 %). Fewer patients died or were hospitalised for worsening heart failure (736 in the placebo group and 613 in the enalapril group; risk reduction, 26 %; 95 % CI, 18 - 34 %; p < 0.0001). Overall in SOLVD study, in patients with left ventricular dysfunction, enalapril reduced the risk of myocardial infarction by 23 % (95 % CI, 11 - 34 %; p < 0.001) and reduced the risk of hospitalisation for unstable angina pectoris by 20% (95 % CI, 9 - 29 %; p < 0.001).

#### Paediatric population

There is limited experience of the use in hypertensive paediatric patients > 6 years. In a clinical study involving 110 hypertensive paediatric patients 6 to 16 years of age with a body weight  $\geq$  20 kg and a glomerular filtration rate > 30 ml/min/1.73 m<sup>2</sup>, patients who weighed < 50 kg received either 0.625, 2.5 or 20 mg of enalapril daily and patients who weighed  $\geq$  50 kg received either 1.25, 5 or 40 mg of enalapril daily.

Enalapril administration once daily lowered trough blood pressure in a dose-dependent manner. The dose-dependent antihypertensive efficacy of enalapril was consistent across all subgroups (age, Tanner stage, gender, race). However, the lowest doses studied, 0.625 mg and 1.25 mg, corresponding to an average of 0.02 mg/kg once daily, did not appear to offer consistent antihypertensive efficacy. The maximum dose studied was 0.58 mg/kg (up to 40 mg) once daily. The adverse experience profile for paediatric patients is not different from that seen in adult patients.

## 5.2 Pharmacokinetic properties

### Absorption

Oral enalapril is rapidly absorbed, with peak serum concentrations of enalapril occurring within one hour. Based on urinary recovery, the extent of absorption of enalapril from oral enalapril tablet is approximately 60 %. The absorption of oral enalapril is not influenced by the presence of food in the gastrointestinal tract.

Following absorption, oral enalapril is rapidly and extensively hydrolysed to enalaprilat, a potent angiotensin converting enzyme inhibitor. Peak serum concentrations of enalaprilat occur about 4 hours after an oral dose of enalapril. The effective half-life for accumulation of enalaprilat following multiple doses of oral enalapril is 11 hours. In subjects with normal renal function, steady-state serum concentrations of enalaprilat were reached after 4 days of treatment.

### Distribution

Over the range of concentrations which are therapeutically relevant, enalaprilat binding to human plasma proteins does not exceed 60 %.

### Biotransformation

Except for conversion to enalaprilat, there is no evidence for significant metabolism of enalapril.

### Elimination

Excretion of enalaprilat is primarily renal. The principal components in urine are enalaprilat, accounting for about 40 % of the dose, and intact enalapril (about 20 %).

### Renal impairment

The exposure of enalapril and enalaprilat is increased in patients with renal insufficiency. In patients with mild to moderate renal insufficiency (creatinine clearance 40-60 ml/min) steady state AUC of enalaprilat was approximately two-fold higher than in patients with normal renal function after administration of 5 mg once daily. In severe renal impairment (creatinine clearance  $\leq$  30 ml/min), AUC was increased approximately 8-fold. The effective half-life of enalaprilat following multiple doses of enalapril is prolonged at this level of renal insufficiency and time to steady state is delayed (see section 4.2). Enalaprilat may be removed from the general circulation by haemodialysis. The dialysis clearance is 62 ml/min.

### Children and adolescents

A multiple dose pharmacokinetic study was conducted in 40 hypertensive male and female paediatric patients aged 2 months to  $\leq$  16 years following daily oral administration of 0.07 to 0.14 mg/kg enalapril. There were no major differences in the pharmacokinetics of enalaprilat in children compared with historic data in adults. The data indicate an increase in AUC (normalised to dose per body weight) with increased



age; however, an increase in AUC is not observed when data are normalised by body surface area. At steady state, the mean effective half-life for accumulation of enalaprilat was 14 hours.

#### Lactation

After a single 20 mg oral dose in five postpartum women the average peak enalapril milk level was 1.7 µg/l (range 0.54 to 5.9 µg/l) at 4 to 6 hours after the dose. The average peak enalaprilat level was 1.7 µg/l (range 1.2 to 2.3 µg/l); peaks occurred at various times over the 24-hour period. Using the peak milk level data, the estimated maximum intake of an exclusively breastfed infant would be about 0.16% of the maternal weight-adjusted dosage.

A woman who had been taking oral enalapril 10 mg daily for 11 months had peak enalapril milk levels of 2 µg/l 4 hours after a dose and peak enalaprilat levels of 0.75 µg/l about 9 hours after the dose. The total amount of enalapril and enalaprilat measured in milk during the 24-hour period was 1.44 µg/l and 0.63 µg/l of milk respectively.

Enalaprilat milk levels were undetectable (< 0.2 µg/l) 4 hours after a single dose of enalapril 5 mg in one mother and 10 mg in two mothers; enalapril levels were not determined.

### **5.3 Preclinical safety data**

Preclinical data reveal no special hazard for humans based on conventional studies of safety pharmacology, repeated dose toxicity, genotoxicity and carcinogenic potential. Reproductive toxicity studies suggest that enalapril has no effects on fertility and reproductive performance in rats and is not teratogenic. In a study in which female rats were dosed prior to mating through gestation, an increased incidence of rat pup deaths occurred during lactation. The compound has been shown to cross the placenta and is secreted in milk. Angiotensin converting enzyme inhibitors, as a class, have been shown to be foetotoxic (causing injury and/or death to the foetus) when given in the second or third trimester.

## **6 PHARMACEUTICAL PARTICULARS**

### **6.1 List of excipients**

Citric acid monohydrate (E330)  
Sodium citrate (E331)  
Sodium benzoate (E211)  
Sucralose (E995)  
Strawberry Flavour  
Purified water

### **6.2 Incompatibilities**

Not applicable

### **6.3 Shelf life**

24 months

Use within 30 days of opening the bottle

### **6.4 Special precautions for storage**

Store in a refrigerator (2°C – 8°C)

Store in the original bottle in order to protect from light

### **6.5 Nature and contents of container**

Bottle: Amber (Type III glass)

Closure: HDPE, EPE wadded, child resistant closure

Oral dosing syringe: polypropylene body, purple HDPE plunger with a capacity of 10ml, with dosage graduation at every 0.5ml, and a bottle adaptor (low density polyethylene).

Pack size: 150ml

Where higher doses are to be administered, 20ml dosing cup should be provided by pharmacist.

### **6.6 Special precautions for disposal**

Any unused medicinal product or waste material should be disposed of in accordance with local requirements.

#### Instructions for use of the oral syringe:

1. To open the bottle, press the cap down and turn it anti-clockwise (figure 1).
2. Put the syringe adaptor into the bottle neck (figure 2).
3. Take the syringe and put it into the adaptor opening (figure 3).
4. Turn the bottle upside down (figure 4).
5. Fill the syringe with a small amount of solution by pulling the plunger down (figure 4A). Then push the plunger upward in order to remove any possible bubbles (figure 4B). Finally, pull the plunger down to the graduation mark corresponding to the quantity in millilitres (ml) prescribed by your doctor. This is given in ml (Figure 4C)
6. Turn the bottle the right way up (Figure 5A).
7. Remove the syringe from the adaptor (Figure 5B).
8. Put the end of the syringe into your mouth and push the plunger slowly back in to take the medicine (Figure 6).
9. Wash the syringe with water and let it dry before you use it again.
10. Close the bottle with the plastic screw cap – leave the syringe adaptor in the bottle.

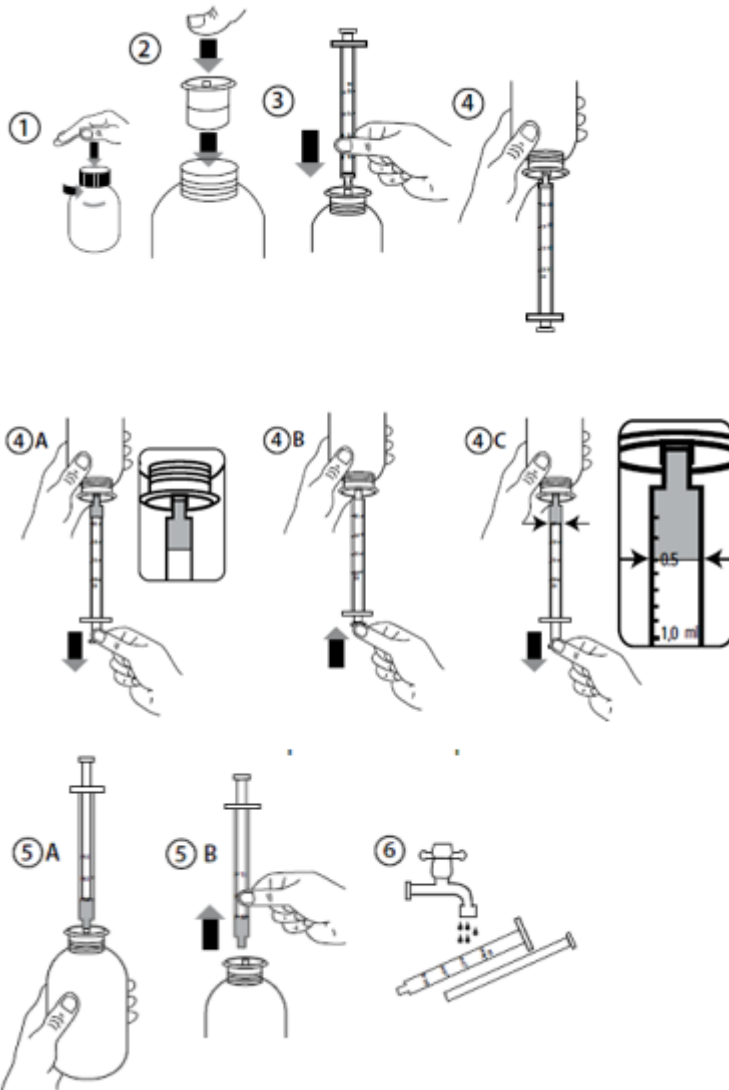

## 7 **MARKETING AUTHORISATION HOLDER**

Rosemont Pharmaceuticals Ltd  
Rosemont House  
Yorkdale Industrial Park  
Braithwaite Street  
Leeds  
LS11 9XE  
UK

## 8 **MARKETING AUTHORISATION NUMBER(S)**

PL 00427/0269

**9 DATE OF FIRST AUTHORISATION/RENEWAL OF THE AUTHORISATION**

18/04/2024

**10 DATE OF REVISION OF THE TEXT**

18/04/2024