

Package leaflet: Information for the user

AMGEVITA 20 mg solution for injection in pre-filled syringe AMGEVITA 40 mg solution for injection in pre-filled syringe adalimumab

▼ This medicine is subject to additional monitoring. This will allow quick identification of new safety information. You can help by reporting any side effects you may get. See the end of section 4 for how to report side effects.

Read all of this leaflet carefully before you start using this medicine because it contains important information for you.

- Keep this leaflet. You may need to read it again.
- Your doctor will also give you a **Patient Reminder Card**, which contains important safety information that you need to be aware of before you are given AMGEVITA and during treatment with AMGEVITA. Keep this **Patient Reminder Card** with you.
- If you have any further questions, ask your doctor or pharmacist.
- This medicine has been prescribed for you only. Do not pass it on to others. It may harm them, even if their signs of illness are the same as yours.
- If you get any side effects, talk to your doctor or pharmacist. This includes any possible side effects not listed in this leaflet (see section 4).

What is in this leaflet

1. What AMGEVITA is and what it is used for
2. What you need to know before you use AMGEVITA
3. How to use AMGEVITA
4. Possible side effects
5. How to store AMGEVITA
6. Contents of the pack and other information

1. What AMGEVITA is and what it is used for

AMGEVITA contains the active substance adalimumab.

AMGEVITA is intended for the treatment of the inflammatory diseases described below:

- Rheumatoid arthritis
- Polyarticular juvenile idiopathic arthritis
- Enthesitis-related arthritis
- Ankylosing spondylitis
- Axial spondyloarthritis without radiographic evidence of ankylosing spondylitis
- Psoriatic arthritis
- Plaque psoriasis
- Hidradenitis suppurativa
- Crohn's disease
- Ulcerative colitis
- Non-infectious uveitis

The active ingredient in AMGEVITA, adalimumab, is a human monoclonal antibody. Monoclonal antibodies are proteins that attach to a specific target.

The target of adalimumab is a protein called tumour necrosis factor (TNF α), which is involved in the immune (defence) system and is present at increased levels in the inflammatory diseases listed above. By attaching to TNF α , AMGEVITA decreases the process of inflammation in these diseases.

Rheumatoid arthritis

Rheumatoid arthritis is an inflammatory disease of the joints.

AMGEVITA is used to treat rheumatoid arthritis in adults. If you have moderate to severe active rheumatoid arthritis, you may first be given other disease-modifying medicines, such as methotrexate. If you do not respond well enough to these medicines, you will be given AMGEVITA to treat your rheumatoid arthritis.

AMGEVITA can also be used to treat severe, active and progressive rheumatoid arthritis without previous methotrexate treatment.

AMGEVITA slows down the damage to the cartilage and bone of the joints caused by the disease and to improve physical function.

Usually, AMGEVITA is used with methotrexate. If your doctor determines that methotrexate is inappropriate, AMGEVITA can be given alone.

Polyarticular juvenile idiopathic arthritis and enthesitis-related arthritis

Polyarticular juvenile idiopathic arthritis and enthesitis-related arthritis are inflammatory diseases.

AMGEVITA is used to treat polyarticular juvenile idiopathic arthritis in patients from 2 years and enthesitis-related arthritis in patients from 6 years. You may first be given other disease-modifying medicines, such as methotrexate. If you do not respond well enough to these medicines, you will be given AMGEVITA to treat your polyarticular juvenile idiopathic arthritis or enthesitis-related arthritis.

Ankylosing spondylitis and axial spondyloarthritis without radiographic evidence of ankylosing spondylitis

Ankylosing spondylitis and axial spondyloarthritis without radiographic evidence of ankylosing spondylitis, are inflammatory diseases of the spine.

AMGEVITA is used to treat ankylosing spondylitis and axial spondyloarthritis without radiographic evidence of ankylosing spondylitis in adults. If you have ankylosing spondylitis or axial spondyloarthritis without radiographic evidence of ankylosing spondylitis, you will first be given other medicines. If you do not respond well enough to these medicines, you will be given AMGEVITA to reduce the signs and symptoms of your disease.

Psoriatic arthritis

Psoriatic arthritis is an inflammation of the joints associated with psoriasis.

AMGEVITA is used to treat psoriatic arthritis in adults. AMGEVITA slows down the damage to the cartilage and bone of the joints caused by the disease and to improve physical function.

Plaque psoriasis in adults and children

Plaque psoriasis is a skin condition that causes red, flaky, crusty patches of skin covered with silvery scales. Plaque psoriasis can also affect the nails, causing them to crumble, become thickened and lift away from the nail bed which can be painful. Psoriasis is believed to be caused by a problem with the body's immune system that leads to an increased production of skin cells.

AMGEVITA is used to treat moderate to severe plaque psoriasis in adults. AMGEVITA is also used to treat severe plaque psoriasis in children and adolescents aged 4 to 17 years for whom topical therapy and phototherapies have either not worked very well or are not suitable.

Hidradenitis suppurativa in adults and adolescents

Hidradenitis suppurativa (sometimes called acne inversa) is a chronic and often painful inflammatory skin disease. Symptoms may include tender nodules (lumps) and abscesses (boils) that may leak pus. It most commonly affects specific areas of the skin, such as under the breasts, the armpits, inner thighs, groin and buttocks. Scarring may also occur in affected areas.

AMGEVITA is used to treat hidradenitis suppurativa in adults and adolescents from 12 years of age. AMGEVITA can reduce the number of nodules and abscesses you have, and the pain that is often associated with the disease. You may first be given other medicines. If you do not respond well enough to these medicines, you will be given AMGEVITA.

Crohn's disease in adults and children

Crohn's disease is an inflammatory disease of the digestive tract.

AMGEVITA is used to treat Crohn's disease in adults and children aged 6 to 17 years. If you have Crohn's disease you will first be given other medicines. If you do not respond well enough to these medicines, you will be given AMGEVITA to reduce the signs and symptoms of your Crohn's disease.

Ulcerative colitis

Ulcerative colitis is an inflammatory disease of the bowel.

AMGEVITA is used to treat ulcerative colitis in adults. If you have ulcerative colitis you will first be given other medicines. If you do not respond well enough to these medicines, you will be given AMGEVITA to reduce the signs and symptoms of your disease.

Non-infectious uveitis in adults and children

Non-infectious uveitis is an inflammatory disease affecting certain parts of the eye.

AMGEVITA is used to treat

- Adults with non-infectious uveitis with inflammation affecting the back of the eye.
- Children from 2 years of age with chronic non-infectious uveitis with inflammation affecting the front of the eye.

This inflammation may lead to a decrease of vision and/or the presence of floaters in the eye (black dots or wispy lines that move across the field of vision). AMGEVITA works by reducing this inflammation.

2. What you need to know before you use AMGEVITA

Do not use AMGEVITA:

- if you are allergic to adalimumab or any of the other ingredients of this medicine (listed in section 6).
- if you have a severe infection, including active tuberculosis (see "Warnings and precautions"). It is important that you tell your doctor if you have symptoms of infections, e.g. fever, wounds, feeling tired, dental problems.
- if you have moderate or severe heart failure. It is important to tell your doctor if you have had or have a serious heart condition (see "Warnings and precautions").

Warnings and precautions

Talk to your doctor or pharmacist before using AMGEVITA:

- If you experience allergic reactions with symptoms such as chest tightness, wheezing, dizziness, swelling or rash do not inject more AMGEVITA and contact your doctor immediately since, in rare cases, these reactions can be life threatening.
- If you have an infection, including long-term or localised infection (for example, leg ulcer) consult your doctor before starting AMGEVITA. If you are unsure, contact your doctor.
- You might get infections more easily while you are receiving AMGEVITA treatment. This risk may increase if your lung function is impaired. These infections may be serious and include tuberculosis, infections caused by viruses, fungi, parasites or bacteria, or other opportunistic infections and sepsis that may, in rare cases, be life-threatening. It is important to tell your doctor if you get symptoms such as fever, wounds, feeling tired or dental problems. Your doctor may recommend temporary discontinuation of AMGEVITA.
- As cases of tuberculosis have been reported in patients treated with adalimumab, your doctor will check you for signs and symptoms of tuberculosis before starting AMGEVITA. This will include a thorough medical evaluation including your medical history and appropriate screening tests (for example chest x-ray and a tuberculin test). The conduct and results of these tests should be recorded on your **Patient Reminder Card**. It is very important that you tell your doctor if you have ever had tuberculosis, or if you have been in close contact with someone who has had tuberculosis. Tuberculosis can develop during therapy even if you have received preventative treatment for tuberculosis. If symptoms of tuberculosis (persistent cough, weight loss, listlessness, mild fever), or any other infection appear during or after therapy, tell your doctor immediately.
- Advise your doctor if you reside or travel in regions where fungal infections such as histoplasmosis coccidioidomycosis or blastomycosis are endemic.
- Advise your doctor if you have a history of recurrent infections or other conditions that increase the risk of infections.
- Advise your doctor if you are a carrier of the hepatitis B virus (HBV), if you have active HBV or if you think you might be at risk of contracting HBV. Your doctor should test you for HBV. AMGEVITA can cause reactivation of HBV in people who carry this virus. In some rare cases, especially if you are taking other medicines that suppress the immune system, reactivation of HBV can be life-threatening.
- If you are over 65 years you may be more susceptible to infections while taking AMGEVITA. You and your doctor should pay special attention to signs of infection while you are being treated with AMGEVITA. It is important to tell your doctor if you get symptoms of infections, such as fever, wounds, feeling tired or dental problems.
- If you are about to undergo surgery or dental procedures please inform your doctor that you are taking AMGEVITA. Your doctor may recommend temporary discontinuation of AMGEVITA.
- If you have or develop demyelinating disease such as multiple sclerosis, your doctor will decide if you should receive or continue to receive AMGEVITA. Tell your doctor immediately if you experience symptoms like changes in your vision, weakness in your arms or legs or numbness or tingling in any part of your body.
- Certain vaccines may cause infections and should not be given while receiving AMGEVITA. Please check with your doctor before you receive any vaccines. It is recommended that children,

if possible, be brought up to date with all immunisations in agreement with current immunisation guidelines prior to initiating AMGEVITA therapy. If you received AMGEVITA while you were pregnant, your baby may be at higher risk for getting such an infection for up to approximately five months after the last dose you received during pregnancy. It is important that you tell your baby's doctors and other health care professionals about your AMGEVITA use during your pregnancy so they can decide when your baby should receive any vaccine.

- If you have mild heart failure and you are being treated with AMGEVITA, your heart failure status must be closely monitored by your doctor. It is important to tell your doctor if you have had or have a serious heart condition. If you develop new or worsening symptoms of heart failure (e.g. shortness of breath, or swelling of your feet), you must contact your doctor immediately. Your doctor will decide if you should receive AMGEVITA.
- In some patients the body may fail to produce enough of the blood cells that help your body fight infections or help you to stop bleeding. If you develop a fever that does not go away, bruise or bleed very easily or look very pale, call your doctor right away. Your doctor may decide to stop treatment.
- There have been very rare cases of certain kinds of cancer in children and adult patients taking adalimumab or other TNF blockers. People with more serious rheumatoid arthritis that have had the disease for a long time may have a higher than average risk of getting lymphoma (a cancer that affects the lymph system), and leukaemia (a cancer that affects the blood and bone marrow). If you take AMGEVITA the risk of getting lymphoma, leukaemia, or other cancers may increase. On rare occasions, a specific and severe type of lymphoma has been observed in patients taking adalimumab. Some of those patients were also treated with azathioprine or 6-mercaptopurine. Tell your doctor if you are taking azathioprine or 6-mercaptopurine with AMGEVITA. In addition, cases of non-melanoma skin cancer have been observed in patients taking adalimumab. If new skin lesions appear during or after therapy or if existing lesions change appearance, tell your doctor.
- There have been cases of cancers, other than lymphoma in patients with a specific type of lung disease called Chronic Obstructive Pulmonary Disease (COPD) treated with another TNF blocker. If you have COPD, or are a heavy smoker, you should discuss with your doctor whether treatment with a TNF blocker is appropriate for you.
- On rare occasions, treatment with AMGEVITA could result in lupus-like syndrome. Contact your doctor if symptoms such as persistent unexplained rash, fever, joint pain or tiredness occur.

In order to improve the traceability of this medicine, your doctor or pharmacist should record the name and the lot number of the product you have been given in your patient file. You may also wish to make a note of these details in case you are asked for this information in the future.

Children and adolescents

- Vaccinations: if possible children should be up to date with all vaccinations before using AMGEVITA.
- Do not give AMGEVITA to children with polyarticular juvenile idiopathic arthritis below the age of 2 years.

Other medicines and AMGEVITA

Tell your doctor or pharmacist if you are taking, have recently taken or might take any other medicines.

AMGEVITA can be taken together with methotrexate or certain disease-modifying anti-rheumatic agents (sulfasalazine, hydroxychloroquine, leflunomide and injectable gold preparations), steroids or pain medications including non-steroidal anti-inflammatory drugs (NSAIDs).

You should not take AMGEVITA with medicines containing the active substances, anakinra or abatacept due to increased risk of serious infection. If you have questions, please ask your doctor.

Pregnancy and breast-feeding

- You should consider the use of adequate contraception to prevent pregnancy and continue its use for at least 5 months after the last AMGEVITA treatment.
- If you are pregnant, think you may be pregnant or are planning to have a baby, ask your doctor for advice about taking this medicine.
- AMGEVITA should only be used during a pregnancy if needed.
- According to a pregnancy study, there was no higher risk of birth defects when the mother had received AMGEVITA during pregnancy compared with mothers with the same disease who did not receive AMGEVITA.
- AMGEVITA can be used during breast-feeding.
- If you receive AMGEVITA during your pregnancy, your baby may have a higher risk for getting an infection.
- It is important that you tell your baby's doctors and other health care professionals about your AMGEVITA use during your pregnancy before the baby receives any vaccine. For more information on vaccines see the "Warnings and precautions" section.

Driving and using machines

AMGEVITA may have a minor influence on your ability to drive, cycle or use machines. Room spinning sensation and vision disturbances may occur after taking AMGEVITA.

AMGEVITA contains sodium

This medicine contains less than 1 mmol of sodium (23 mg) per 0.8 mL dose, i.e. essentially 'sodium-free'.

3. How to use AMGEVITA

Always use this medicine exactly as your doctor or pharmacist has told you. Check with your doctor or pharmacist if you are not sure.

Adults with rheumatoid arthritis, psoriatic arthritis, ankylosing spondylitis or axial spondyloarthritis without radiographic evidence of ankylosing spondylitis

AMGEVITA is injected under the skin (subcutaneous use). The usual dose for adults with rheumatoid arthritis, ankylosing spondylitis, axial spondyloarthritis without radiographic evidence of ankylosing spondylitis, and for patients with psoriatic arthritis is 40 mg given every other week as a single dose.

In rheumatoid arthritis, methotrexate is continued while using AMGEVITA. If your doctor determines that methotrexate is inappropriate, AMGEVITA can be given alone.

If you have rheumatoid arthritis and you do not receive methotrexate with your AMGEVITA therapy, your doctor may decide to give 40 mg every week or 80 mg every other week.

Children, adolescents and adults with polyarticular juvenile idiopathic arthritis

Children and adolescents from 2 years of age weighing 10 kg to less than 30 kg

The recommended dose of AMGEVITA is 20 mg every other week.

Children, adolescents and adults from 2 years of age weighing 30 kg or more

The recommended dose of AMGEVITA is 40 mg every other week.

Children, adolescents and adults with enthesitis-related arthritis

Children and adolescents from 6 years of age weighing 15 kg to less than 30 kg

The recommended dose of AMGEVITA is 20 mg every other week.

Children, adolescents and adults from 6 years of age weighing 30 kg or more

The recommended dose of AMGEVITA is 40 mg every other week.

Adults with plaque psoriasis

The usual dose for adults with plaque psoriasis is an initial dose of 80 mg (as two 40 mg injections in one day), followed by 40 mg given every other week starting one week after the initial dose. You should continue to inject AMGEVITA for as long as your doctor has told you. Depending on your response, your doctor may increase the dosage to 40 mg every week or 80 mg every other week.

Children and adolescents with plaque psoriasis

Children and adolescents from 4 to 17 years of age weighing 15 kg to less than 30 kg

The recommended dose of AMGEVITA is an initial dose of 20 mg, followed by 20 mg one week later. Thereafter, the usual dose is 20 mg every other week.

Children and adolescents from 4 to 17 years of age weighing 30 kg or more

The recommended dose of AMGEVITA is an initial dose of 40 mg, followed by 40 mg one week later. Thereafter, the usual dose is 40 mg every other week.

Adults with hidradenitis suppurativa

The usual dose regimen for hidradenitis suppurativa is an initial dose of 160 mg (as four 40 mg injections in one day or two 40 mg injections per day for two consecutive days), followed by an 80 mg dose (as two 40 mg injections in one day) two weeks later. After two further weeks, continue with a dose of 40 mg every week or 80 mg every other week, as prescribed by your doctor. It is recommended that you use an antiseptic wash daily on the affected areas.

Adolescents with hidradenitis suppurativa from 12 to 17 years of age weighing 30 kg or more

The recommended dose of AMGEVITA is an initial dose of 80 mg (as two 40 mg injections in one day), followed by 40 mg every other week starting one week later. If you have an inadequate response to AMGEVITA 40 mg every other week, your doctor may increase the dosage to 40 mg every week or 80 mg every other week.

It is recommended that you use an antiseptic wash daily on the affected areas.

Adults with Crohn's disease

The usual dose regimen for Crohn's disease is 80 mg (as two 40 mg injections in one day) initially followed by 40 mg every other week two weeks later. If a faster response is required, your doctor may prescribe an initial dose of 160 mg (as four 40 mg injections in one day or two 40 mg injections per day for two consecutive days), followed by 80 mg (as two 40 mg injections in one day) two weeks later, and thereafter as 40 mg every other week. Depending on your response, your doctor may increase the dosage to 40 mg every week or 80 mg every other week.

Children and adolescents with Crohn's disease

Children and adolescents from 6 to 17 years of age weighing less than 40 kg

The usual dose regimen is 40 mg initially followed by 20 mg two weeks later. If a faster response is required, your doctor may prescribe an initial dose of 80 mg (as two 40 mg injections in one day) followed by 40 mg two weeks later.

Thereafter, the usual dose is 20 mg every other week. Depending on your response, your doctor may increase the dose frequency to 20 mg every week.

Children and adolescents from 6 to 17 years of age weighing 40 kg or more

The usual dose regimen is 80 mg (as two 40 mg injections in one day) initially followed by 40 mg two weeks later. If a faster response is required, your doctor may prescribe an initial dose of 160 mg (as four 40 mg injections in one day or as two 40 mg injections per day for two consecutive days) followed by 80 mg (as two 40 mg injections in one day) two weeks later.

Thereafter, the usual dose is 40 mg every other week. Depending on your response, your doctor may increase the dosage to 40 mg every week or 80 mg every other week.

Adults with ulcerative colitis

The usual AMGEVITA dose for adults with ulcerative colitis is 160 mg initially (as four 40 mg injections in one day or as two 40 mg injections per day for two consecutive days) followed by 80 mg (as two 40 mg injections in one day) two weeks later, then 40 mg every other week. Depending on your response, your doctor may increase the dosage to 40 mg every week or 80 mg every other week.

Adults with non-infectious uveitis

The usual dose for adults with non-infectious uveitis is an initial dose of 80 mg (as two 40 mg injections in one day), followed by 40 mg given every other week starting one week after the initial dose. You should continue to inject AMGEVITA for as long as your doctor has told you.

In non-infectious uveitis, corticosteroids or other medicines that influence the immune system may be continued while using AMGEVITA. AMGEVITA can also be given alone.

Children and adolescents with chronic non-infectious uveitis from 2 years of age

Children and adolescents from 2 years of age weighing less than 30 kg

The usual dose of AMGEVITA is 20 mg every other week with methotrexate.

Your doctor may also prescribe an initial dose of 40 mg which may be administered one week prior to the start of the usual dose.

Children and adolescents from 2 years of age weighing 30 kg or more

The usual dose of AMGEVITA is 40 mg every other week with methotrexate.

Your doctor may also prescribe an initial dose of 80 mg which may be administered one week prior to the start of the usual dose.

Method and route of administration

AMGEVITA is administered by injection under the skin (subcutaneous injection).

If you use more AMGEVITA than you should

If you accidentally inject AMGEVITA more frequently than told to by your doctor or pharmacist, call your doctor or pharmacist and tell him/her that you have taken more. Always take the outer carton of this medicine with you, even if it is empty.

If you forget to use AMGEVITA

If you forget to give yourself an injection, you should inject the next dose of AMGEVITA as soon as you remember. Then take your next dose as you would have on your originally scheduled day, had you not forgotten a dose.

If you stop using AMGEVITA

The decision to stop using AMGEVITA should be discussed with your doctor. Your symptoms may return upon discontinuation.

If you have any further questions on the use of this medicine, ask your doctor or pharmacist.

4. Possible side effects

Like all medicines, this medicine can cause side effects, although not everybody gets them. Most side effects are mild to moderate. However, some may be serious and require treatment. Side effects may occur at least up to 4 months after the last AMGEVITA injection.

Tell your doctor immediately if you notice any of the following

- severe rash, hives or other signs of allergic reaction;
- swollen face, hands, feet;
- trouble breathing, swallowing;
- shortness of breath with exertion or upon lying down or swelling of the feet.

Tell your doctor as soon as possible if you notice any of the following

- signs of infection such as fever, feeling sick, wounds, dental problems, burning on urination;
- feeling weak or tired;
- coughing;
- tingling;
- numbness;
- double vision;
- arm or leg weakness;
- a bump or open sore that doesn't heal;
- signs and symptoms suggestive of blood disorders such as persistent fever, bruising, bleeding, paleness.

The symptoms described above can be signs of the below listed side effects, which have been observed with adalimumab.

Very common (may affect more than 1 in 10 people)

- injection site reactions (including pain, swelling, redness or itching);
- respiratory tract infections (including cold, runny nose, sinus infection, pneumonia);
- headache;
- abdominal pain;
- nausea and vomiting;
- rash;
- musculoskeletal pain.

Common (may affect up to 1 in 10 people)

- serious infections (including blood poisoning and influenza);
- intestinal infections (including gastroenteritis);
- skin infections (including cellulitis and shingles);
- ear infections;
- oral infections (including tooth infections and cold sores);
- reproductive tract infections;
- urinary tract infection;
- fungal infections;
- joint infections;
- benign tumours;
- skin cancer;
- allergic reactions (including seasonal allergy);
- dehydration;
- mood swings (including depression);
- anxiety;
- difficulty sleeping;
- sensation disorders such as tingling, prickling or numbness;
- migraine;
- nerve root compression (including low back pain and leg pain);
- vision disturbances;
- eye inflammation;
- inflammation of the eye lid and eye swelling;
- vertigo;
- sensation of heart beating rapidly;
- high blood pressure;
- flushing;
- haematoma;
- cough;
- asthma;
- shortness of breath;
- gastrointestinal bleeding;
- dyspepsia (indigestion, bloating, heart burn);
- acid reflux disease;
- sicca syndrome (including dry eyes and dry mouth);
- itching;
- itchy rash;
- bruising;
- inflammation of the skin (such as eczema);
- breaking of finger nails and toe nails;
- increased sweating;
- hair loss;
- new onset or worsening of psoriasis;
- muscle spasms;
- blood in urine;
- kidney problems;

- chest pain;
- oedema;
- fever;
- reduction in blood platelets which increases risk of bleeding or bruising;
- impaired healing.

Uncommon (may affect up to 1 in 100 people)

- opportunistic infections (which include tuberculosis and other infections that occur when resistance to disease is lowered);
- neurological infections (including viral meningitis);
- eye infections;
- bacterial infections;
- diverticulitis (inflammation and infection of the large intestine);
- cancer;
- cancer that affects the lymph system;
- melanoma;
- immune disorders that could affect the lungs, skin and lymph nodes (most commonly presenting as sarcoidosis);
- vasculitis (inflammation of blood vessels);
- tremor;
- neuropathy;
- stroke;
- hearing loss, buzzing;
- sensation of heart beating irregularly such as skipped beats;
- heart problems that can cause shortness of breath or ankle swelling;
- heart attack;
- a sac in the wall of a major artery, inflammation and clot of a vein, blockage of a blood vessel;
- lung diseases causing shortness of breath (including inflammation);
- pulmonary embolism (blockage in an artery of the lung);
- pleural effusion (abnormal collection of fluid in the pleural space);
- inflammation of the pancreas which causes severe pain in the abdomen and back;
- difficulty in swallowing;
- facial oedema;
- gallbladder inflammation, gallbladder stones;
- fatty liver;
- night sweats;
- scar;
- abnormal muscle breakdown;
- systemic lupus erythematosus (including inflammation of skin, heart, lung, joints and other organ systems);
- sleep interruptions;
- impotence;
- inflammations.

Rare (may affect up to 1 in 1,000 people)

- leukaemia (cancer affecting the blood and bone marrow);
- severe allergic reaction with shock;
- multiple sclerosis;
- nerve disorders (such as eye nerve inflammation and Guillain-Barré syndrome that may cause muscle weakness, abnormal sensations, tingling in the arms and upper body);
- heart stops pumping;
- pulmonary fibrosis (scarring of the lung);
- intestinal perforation;
- hepatitis;
- reactivation of hepatitis B;
- autoimmune hepatitis (inflammation of the liver caused by the body's own immune system);

- cutaneous vasculitis (inflammation of blood vessels in the skin);
- Stevens-Johnson syndrome (early symptoms include malaise, fever, headache and rash);
- facial oedema associated with allergic reactions;
- erythema multiforme (inflammatory skin rash);
- lupus-like syndrome;
- angioedema (localised swelling of the skin);
- lichenoid skin reaction (itchy reddish-purple skin rash).

Not known (frequency cannot be estimated from available data)

- hepatosplenic T-cell lymphoma (a rare blood cancer that is often fatal);
- Merkel cell carcinoma (a type of skin cancer);
- liver failure;
- worsening of a condition called dermatomyositis (seen as a skin rash accompanying muscle weakness).

Some side effects observed with adalimumab may not have symptoms and may only be discovered through blood tests. These include:

Very common (may affect more than 1 in 10 people)

- low blood measurements for white blood cells;
- low blood measurements for red blood cells;
- increased lipids in the blood;
- elevated liver enzymes.

Common (may affect up to 1 in 10 people)

- high blood measurements for white blood cells;
- low blood measurements for platelets;
- increased uric acid in the blood;
- abnormal blood measurements for sodium;
- low blood measurements for calcium;
- low blood measurements for phosphate;
- high blood sugar;
- high blood measurements for lactate dehydrogenase;
- autoantibodies present in the blood;
- low blood potassium.

Uncommon (may affect up to 1 in 100 people)

- elevated bilirubin measurement (liver blood test).

Rare (may affect up to 1 in 1,000 people)

- low blood measurements for white blood cells, red blood cells and platelet count.

Reporting of side effects

If you get any side effects, talk to your doctor or pharmacist. This includes any possible side effects not listed in this leaflet. You can also report side effects directly (see details below). By reporting side effects you can help provide more information on the safety of this medicine.

Yellow Card Scheme

Website: www.mhra.gov.uk/yellowcard or search for MHRA Yellow Card in the Google Play or Apple App Store

5. How to store AMGEVITA

Keep this medicine out of the sight and reach of children.

Do not use this medicine after the expiry date which is stated on the label and carton after EXP. The expiry date refers to the last day of that month.

Store in a refrigerator (2°C – 8°C). Do not freeze.

Store in the original carton in order to protect from light.

A single AMGEVITA pre-filled syringe may be stored at temperatures up to a maximum of 25°C for a period of up to 14 days. The pre-filled syringe must be protected from light, and discarded if not used within the 14-day period.

Do not throw away any medicines via wastewater or household waste. Ask your pharmacist how to throw away medicines you no longer use. These measures will help protect the environment.

6. Contents of the pack and other information

What AMGEVITA contains

- The active substance is adalimumab. Each pre-filled syringe contains 20 mg of adalimumab in 0.4 mL of solution or 40 mg of adalimumab in 0.8 mL of solution.
- The other ingredients are glacial acetic acid, sucrose, polysorbate 80, sodium hydroxide and water for injection.

What AMGEVITA looks like and contents of the pack

AMGEVITA is a clear and colourless to slightly yellow solution.

Each pack contains 1 single-use 20 mg pre-filled syringe (with yellow plunger rod).

Each pack contains 1, 2, 4 or 6 single-use 40 mg pre-filled syringes (with blue plunger rod).

Marketing Authorisation Holder

Amgen Limited
216 Cambridge Science park
Milton Road
Cambridge
CB4 0FZ
United Kingdom

Manufacturer

Amgen Europe B.V.
Minervum 7061
NL-4817 ZK Breda
The Netherlands

Manufacturer

Amgen Technology Ireland UC
Pottery Road
Dun Laoghaire
Co Dublin
Ireland

For any information about this medicine, please contact the local representative of the Marketing Authorisation Holder:

Amgen Limited
Tel: +44 (0)1223 420305

This leaflet was last revised in January 2021.

Instructions for use:
 AMGEVITA single use pre-filled syringe
 For subcutaneous use

Guide to parts

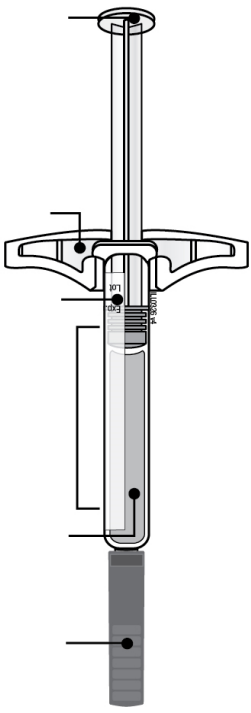
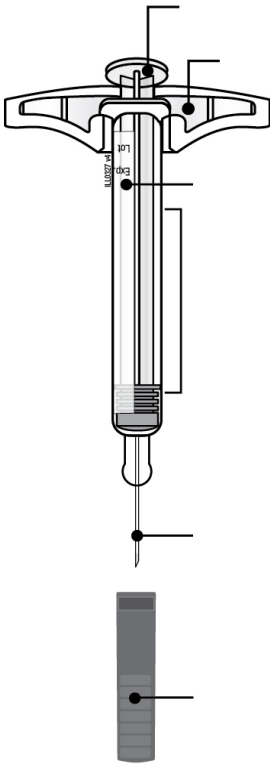
Before use	After use
<p>Plunger rod</p> <p>Finger flange</p> <p>Label and expiration date</p> <p>Syringe barrel</p> <p>Medicine</p> <p>Needle cap on</p> 	<p>Used plunger rod</p> <p>Finger flange</p> <p>Label and expiration date</p> <p>Used syringe barrel</p> <p>Used needle</p> <p>Needle cap off</p> 

Important: Needle is inside

Important

Before you use an AMGEVITA pre-filled syringe, read this important information:

Using your AMGEVITA pre-filled syringe

- It is important that you do not try to give the injection unless you or your caregiver has received training.
- **Do not** use an AMGEVITA pre-filled syringe if it has been dropped on a hard surface. Part of the AMGEVITA pre-filled syringe may be broken even if you cannot see the break. Use a new AMGEVITA pre-filled syringe.

Step 1: Prepare

- A. Remove the number of AMGEVITA pre-filled syringes you need from the package.

Grab the syringe barrel to remove the syringe from the tray.

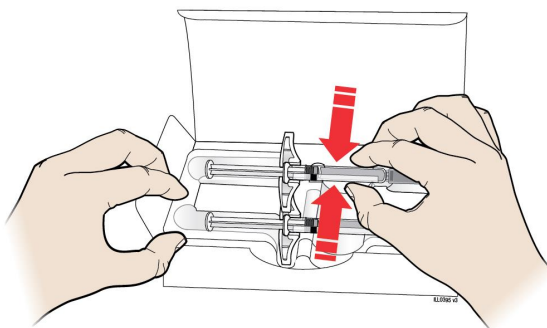
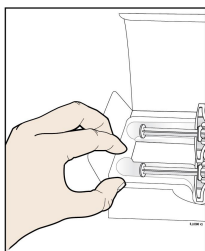

Grab Here

Place your finger or thumb on edge of tray to secure it while you remove the syringe.

Put the original package with any unused syringes back in the refrigerator.

For safety reasons:

- **Do not** grasp the plunger rod.
- **Do not** grasp the needle cap.
- **Do not** remove the needle cap until you are ready to inject.
- **Do not** remove the finger flange. This is part of the syringe.

For a more comfortable injection, leave the syringe at room temperature for **15 to 30** minutes before injecting.

- **Do not** put the syringe back in the refrigerator once it has reached room temperature.
- **Do not** try to warm the syringe by using a heat source such as hot water or microwave.
- **Do not** leave the syringe in direct sunlight.
- **Do not** shake the syringe.

Important: Always hold the pre-filled syringe by the syringe barrel.

B. Inspect the AMGEVITA pre-filled syringe.

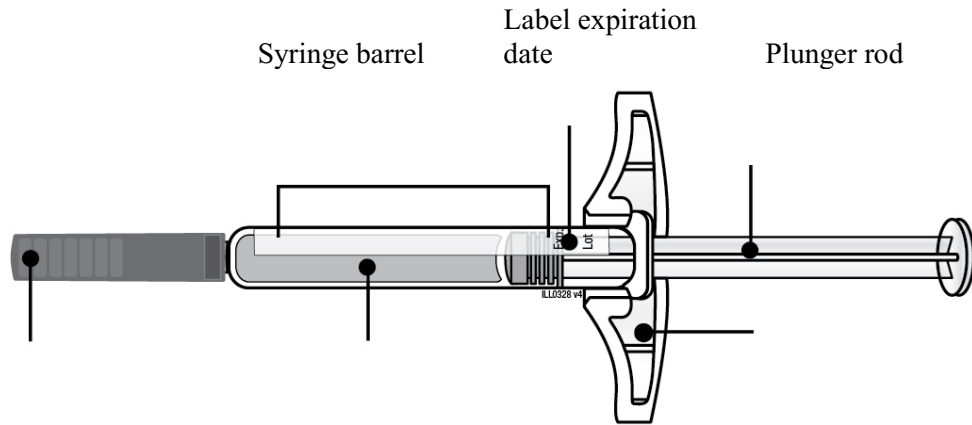

Always hold the syringe by the syringe barrel.

Make sure the medicine in the syringe is clear and colourless to slightly yellow.

- **Do not** use the syringe if:
 - The medicine is cloudy or discoloured or contains flakes, or particles.
 - Any part appears cracked or broken.
 - The needle cap is missing or not securely attached.
 - The expiration date printed on the label has passed.

In all cases, use a new syringe.

C. Gather all materials needed for your injection(s).

Wash your hands thoroughly with soap and water.
On a clean, well-lit work surface, place a new, pre-filled syringe.

You will also need these additional items, as they are not included in the carton:

- Alcohol wipes
- Cotton ball or gauze pad
- Plaster
- Sharps disposal container

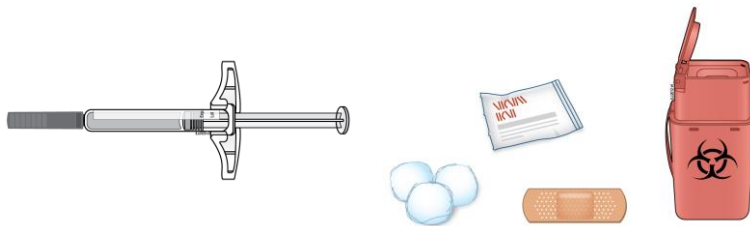

D. Prepare and clean your injection site(s).

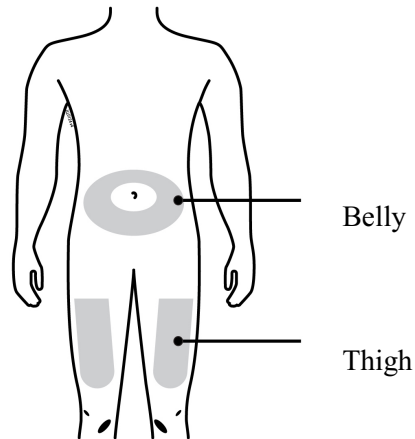

You can use:

- Your thigh
- Belly, except for a 2 inch (5 centimetres) area around your belly button

Clean your injection site with an alcohol wipe. Let your skin dry.

- **Do not** touch this area again before injecting.
- If you want to use the same injection site, make sure it is not the same spot on the injection site you used for a previous injection.
 - **Do not** inject into areas where the skin is tender, bruised, red, or hard. Avoid injecting into areas with scars or stretch marks.
- If you have psoriasis, you should avoid injecting directly into raised, thick, red, or scaly skin patch or lesion.

Step 2: Get ready

E. Pull the needle cap straight out and away from your body when you are ready to inject.

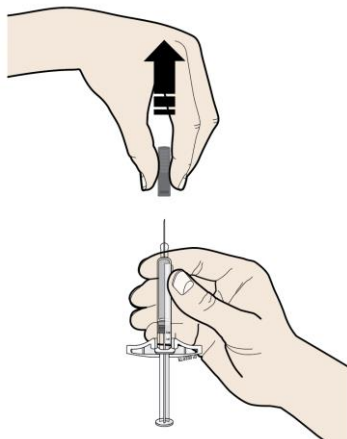

It is normal to see a drop of liquid at the end of the needle.

- **Do not** twist or bend the needle cap.
- **Do not** put the needle cap back onto the syringe.
- **Do not** remove the needle cap from the syringe until you are ready to inject.

Important: Throw the needle cap into the sharps disposal container provided.

F. Pinch your injection site to create a firm surface.

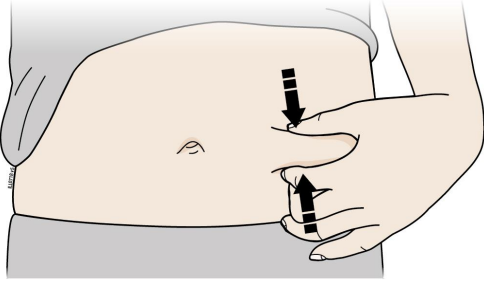

Pinch the skin firmly between your thumb and fingers, creating an area about 2 inch (5 centimetres) wide.

Important: Keep the skin pinched while injecting.

Step 3: Inject

G. Hold the pinch. With the needle cap off, insert the syringe into your skin at 45 to 90 degrees.

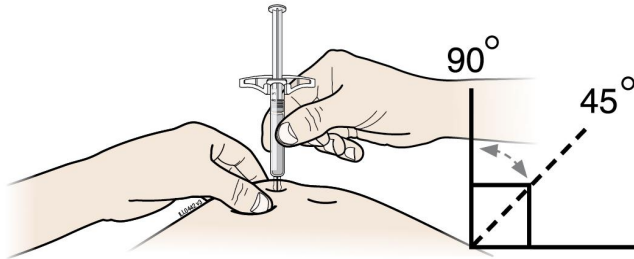

Do not place your finger on the plunger rod while inserting the needle.

H. Using slow and constant pressure, push the plunger rod all the way down until it stops moving.

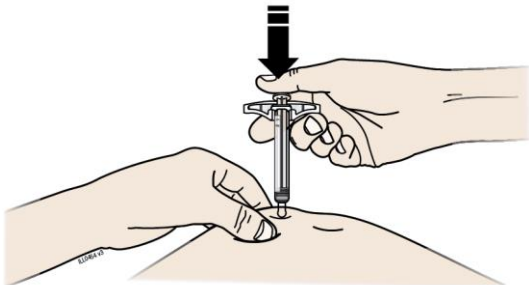

I. When done, release your thumb, and gently lift the syringe off of your skin.

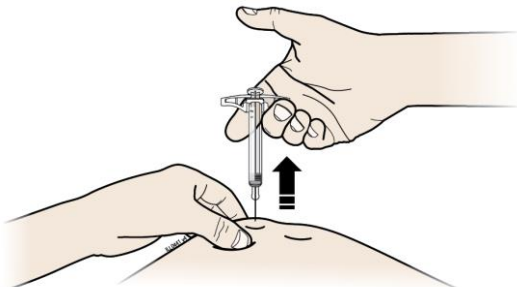

Step 4: Finish

J. Discard the used syringe and the needle cap.



- **Do not** reuse the used syringe.
- **Do not** use any medicine that is left in the used syringe.
- Put the used AMGEVITA syringe in a sharps disposal container immediately after use. **Do not** throw away (dispose of) the syringe in your household waste.
- Talk with your doctor or pharmacist about proper disposal. There may be local guidelines for disposal.
- **Do not** recycle the syringe or sharps disposal container or throw them into the household waste.

Important: Always keep the sharps disposal container out of the sight and reach of children.

K. Examine the injection site.

If there is blood, press a cotton ball or gauze pad on your injection site. **Do not** rub the injection site. Apply a plaster if needed.