

# Aranesp® 300 micrograms solution for injection in pre-filled syringe (darbepoetin alfa)

## Read all of this leaflet carefully before you start using this medicine because it contains important information for you.

- Keep this leaflet. You may need to read it again.
- If you have any further questions, ask your doctor, pharmacist or nurse.
- This medicine has been prescribed for you only. Do not pass it on to others. It may harm them, even if their signs of illness are the same as yours.
- If you get any side effects, talk to your doctor, pharmacist or nurse. This includes any possible side effects not listed in this leaflet (see section 4).

This product is called Aranesp 300 micrograms solution for injection in pre-filled syringe but will be referred to as Aranesp throughout the leaflet.

### What is in this leaflet

1. What Aranesp is and what it is used for
2. What you need to know before you use Aranesp
3. How to use Aranesp
4. Possible side effects
5. How to store Aranesp
6. Contents of the pack and other information

### 1. What Aranesp is and what it is used for

Your doctor has given you Aranesp (an anti-anaemic) to treat your anaemia. Anaemia is when your blood does not contain enough red blood cells and the symptoms may be fatigue, weakness and shortness of breath.

Aranesp works in exactly the same way as the natural hormone erythropoietin. Erythropoietin is produced in your kidneys and encourages your bone marrow to produce more red blood cells. The active substance of Aranesp is darbepoetin alfa produced by gene-technology in Chinese Hamster Ovary Cells (CHO-K1).

### If you have chronic renal failure

Aranesp is used to treat symptomatic anaemia that is associated with chronic renal failure (kidney failure) in adults and children. In kidney failure, the kidney does not produce enough of the natural hormone erythropoietin which can often cause anaemia.

Because it will take your body some time to make more red blood cells, it will be about four weeks before you notice any effect. Your normal dialysis routine will not affect the ability of Aranesp to treat your anaemia.

### If you are receiving chemotherapy

Aranesp is used to treat symptomatic anaemia in adult cancer patients with non-bone marrow cancers (non-myeloid malignancies) who are receiving chemotherapy.

One of the main side effects of chemotherapy is that it stops the bone marrow producing enough blood cells. Towards the end of your chemotherapy course, particularly if you have had a lot of chemotherapy, your red blood cell count may fall making you anaemic.

### 2. What you need to know before you use Aranesp

#### Do not use Aranesp:

- if you are allergic to darbepoetin alfa or any of the other ingredients of this medicine listed in section 6.
- if you have been diagnosed with high blood pressure which is not being controlled with other medicines prescribed by your doctor.

### Warnings and precautions

Talk to your doctor, pharmacist or nurse before using Aranesp.

- Please tell your doctor if you are **suffering** or **have suffered** from:
- high blood pressure which is being controlled with medicines prescribed by your doctor;
  - sickle cell anaemia;
  - epileptic fits (seizures);
  - convulsions (fits or seizures);
  - liver disease;
  - significant lack of response to medicines used to treat anaemia;
  - an allergy to latex (the needle cap on the pre-filled syringe contains a derivative of latex); or
  - hepatitis C.

#### Special warnings:

- If you have symptoms which include unusual tiredness and a lack of energy this could mean you have pure red cell aplasia (PRCA), which has been reported in patients. PRCA means that the body has stopped or reduced the production of red blood cells which causes severe anaemia. If you experience these symptoms you should contact your doctor who will determine the best course of action to treat your anaemia.

- Take special care with other products that stimulate red blood cell production: Aranesp is one of a group of products that stimulate the production of red blood cells like the human protein erythropoietin does. Your healthcare professional should always record the exact product you are using.

- If you are a patient with chronic renal failure, and particularly if you do not respond properly to Aranesp, your doctor will check your dose of Aranesp because repeatedly increasing your dose of Aranesp if you are not responding to treatment may increase the risk of having a problem of the heart or the blood vessels and could increase risk of myocardial infarction, stroke and death.

- Your doctor should try to keep your haemoglobin between 10 and 12 g/dL. Your doctor will check that your haemoglobin does not exceed a certain level, as high haemoglobin concentrations could put you at risk of having a problem of the heart or the blood vessels and could increase risk of myocardial infarction, stroke and death.

- If you have symptoms which include severe headache, drowsiness, confusion, problems with your eyesight, nausea, vomiting or fits (seizures), it could mean that you have very high blood pressure. If you experience these symptoms you should contact your doctor.

- If you are a cancer patient you should be aware that Aranesp may act as a blood cell growth factor and in some circumstances may have a negative impact on your cancer. Depending on your individual situation a blood transfusion may be preferable. Please discuss this with your doctor.

- Misuse by healthy people can cause life-threatening problems with the heart or blood vessels.

- Serious skin reactions including Stevens-Johnson syndrome (SJS) and toxic epidermal necrolysis (TEN) have been reported in association with epoetin treatment. SJS/TEN can appear initially as reddish target-like spots or circular patches often with central blisters on the trunk. Also, ulcers of mouth, throat, nose, genitals and eyes (red and swollen eyes) can occur. These serious skin rashes are often preceded by fever and/or flu-like symptoms. The rashes may progress to widespread peeling of the skin and life-threatening complications. If you develop a serious rash or another of these skin symptoms, stop taking Aranesp and contact your doctor or seek medical attention immediately.

### Other medicines and Aranesp

Tell your doctor or pharmacist if you are using, have recently used or might use any other medicines.

Cyclosporin and tacrolimus (medicines which suppress the immune system) may be affected by the number of red cells in your blood. It is important to tell your doctor if you are taking either of these medicines.

### Using Aranesp with food and drink

Food and drink do not affect Aranesp.

### Pregnancy and breast-feeding

If you are pregnant or breast-feeding, think you may be pregnant or are planning to have a baby, ask your doctor or pharmacist for advice before taking this medicine.

Aranesp has not been tested in pregnant women. It is important to tell your doctor if you:

- are pregnant;
- think you may be pregnant; or
- plan to get pregnant.

It is not known whether darbepoetin alfa is excreted in human milk. You must stop breast-feeding if you use Aranesp.

### Driving and using machines

Aranesp should not affect your ability to drive or use machinery.

### Aranesp contains sodium

This medicine contains less than 1 mmol sodium (23 mg) per dose, that is to say essentially 'sodium-free'.

### 3. How to use Aranesp

Always use this medicine exactly as your doctor or pharmacist has told you. Check with your doctor or pharmacist if you are not sure.

Following blood tests, your doctor has decided you need Aranesp as your haemoglobin level is 10 g/dL or less. Your doctor will tell you how much and how often you must take Aranesp in order to maintain a haemoglobin level between 10 and 12 g/dL. This may vary depending on whether you are an adult or a child.

### Injecting Aranesp yourself

Your doctor may decide that it is best for you or a carer to inject Aranesp. Your doctor, nurse or pharmacist will show you how to inject yourself with the pre-filled syringe. Do not try to inject yourself if you have not been trained. **Never inject Aranesp into a vein yourself.**

### If you have chronic renal failure

For all adult and paediatric patients ≥ 1 year of age with chronic renal failure, Aranesp is given as a single injection, either under your skin (subcutaneous) or into a vein (intravenous). In order to correct your anaemia, your initial dose of Aranesp per kilogram of your body weight will be either:

- 0.75 micrograms once every two weeks, or
- 0.45 micrograms once weekly.

For adult patients not on dialysis, 1.5 micrograms/kg once monthly may also be used as the initial dose.

For all adult and paediatric patients ≥ 1 year of age with chronic renal failure, once your anaemia is corrected you will continue to receive Aranesp given as a single injection, either once a week or once every two weeks. For all adults and paediatric patients ≥ 11 years of age not on dialysis, Aranesp could also be given as an injection once monthly.

Your doctor will take regular blood samples to measure how your anaemia is responding and may adjust your dose once every four weeks as necessary in order to maintain long term control of your anaemia.

Your doctor will use the lowest effective dose to control the symptoms of your anaemia.

If you do not respond adequately to Aranesp, your doctor will check your dose and will inform you if you need to change doses of Aranesp.

Your blood pressure will also be checked regularly, particularly at the beginning of your treatment.

In some cases, your doctor may recommend that you take iron supplements.

Your doctor may decide to change the way that your injection is given (either under the skin or into a vein). If this changes you will start on the same dose as you have been receiving and your doctor will take blood samples to make sure that your anaemia is still being managed correctly.

If your doctor has decided to change your treatment from r-HuEPO (erythropoietin produced by gene-technology) to Aranesp, they will choose whether you should receive your Aranesp injection once weekly or once every two weeks. The route of injection is the same as with r-HuEPO but your doctor will tell you how much you should take, and when, and may adjust your dose if necessary.

### If you are receiving chemotherapy

Aranesp is given as a single injection, either once a week or once every three weeks, under your skin.

In order to correct your anaemia, your initial dose will be:

- 500 micrograms once every three weeks (6.75 micrograms of Aranesp per kilogram of your body weight); or
- 2.25 micrograms (once weekly) of Aranesp per kilogram of your body weight.

Your doctor will take regular blood samples to measure how your anaemia is responding and may adjust your dose as necessary. Your treatment will continue until approximately four weeks after the end of your chemotherapy. Your doctor will tell you exactly when to stop taking Aranesp.

In some cases, your doctor may recommend that you take iron supplements.

### If you use more Aranesp than you should

You could have serious problems if you use more Aranesp than you need, such as very high blood pressure. You should contact your doctor, nurse or pharmacist if this does happen. If you feel unwell in any way you should contact your doctor, nurse or pharmacist immediately.

### If you forget to use Aranesp

Do not use a double dose to make up for a forgotten dose.

If you have forgotten a dose of Aranesp, you should contact your doctor to discuss when you should inject the next dose.

### If you stop using Aranesp

If you want to stop using Aranesp, you should discuss it with your doctor first.

### 4. Possible side effects

Like all medicines, this medicine can cause side effects, although not everybody gets them.

#### The following side effects have been experienced by some patients taking Aranesp:

#### Chronic renal failure patients

- Very common:** may affect more than 1 in 10 people
- High blood pressure (hypertension)
  - Allergic reactions

- Common:** may affect up to 1 in 10 people
- Stroke
  - Pain around the area injected
  - Rash and/or redness of the skin

- Uncommon:** may affect up to 1 in 100 people
- Blood clots (thrombosis)
  - Convulsions (fits and seizures)
  - Bruising and bleeding at the site of injection
  - Blood clots in a dialysis access

- Not known:** frequency cannot be estimated from available data
- Pure red cell aplasia (PRCA)
    - (anaemia, unusual tiredness, lack of energy)

### Cancer patients

- Very common:** may affect more than 1 in 10 people
- Allergic reactions

- Common:** may affect up to 1 in 10 people
- High blood pressure (hypertension)
  - Blood clots (thrombosis)
  - Pain around the area injected
  - Rash and/or redness of the skin
  - Fluid retention (oedema)

- Uncommon:** may affect up to 1 in 100 people
- Convulsions (fits and seizures)
  - Bruising and bleeding at the site of injection

### All patients

**Not known:** frequency cannot be estimated from available data

- Serious allergic reactions which may include:
  - Sudden life-threatening allergic reactions (anaphylaxis)
  - Swelling of the face, lips, mouth, tongue or throat which may cause difficulty in swallowing or breathing (angioedema)
  - Shortness of breath (allergic bronchospasm)
  - Skin rash
  - Hives (urticaria)
- Serious skin rashes including Stevens-Johnson syndrome and toxic epidermal necrolysis have been reported in association with epoetin treatment. These can appear as reddish target-like macules or circular patches often with central blisters on the trunk, skin peeling, ulcers of mouth, throat, nose, genitals and eyes and can be preceded by fever and flu-like symptoms. Stop using Aranesp if you develop these symptoms and contact your doctor or seek medical attention immediately (see section 2).

### Reporting of side effects

If you get any side effects, talk to your doctor, pharmacist or nurse. This includes any possible side effects not listed in this leaflet. You can also report side effects directly (see details below). By reporting side effects you can help provide more information on the safety of this medicine.

Yellow Card Scheme  
Website: [www.mhra.gov.uk/yellowcard](http://www.mhra.gov.uk/yellowcard) or search for MHRA Yellow Card in the Google Play or Apple App Store

### 5. How to store Aranesp

Keep this medicine out of the sight and reach of children.

Do not use this medicine after the expiry date which is stated on the carton and on the pre-filled syringe label after EXP. The expiry date refers to the last day of that month.

Store in a refrigerator (2°C - 8°C). Do not freeze. Do not use Aranesp if you think it has been frozen.

Keep the pre-filled syringe in the outer carton in order to protect from light.

When your syringe has been removed from the refrigerator and left at room temperature for approximately 30 minutes before injection it must either be used within 7 days or disposed of.

Do not use this medicine if you notice the pre-filled syringe contents are cloudy or there are particles in it.

Do not throw away any medicines via wastewater or household waste. Ask your pharmacist how to throw away medicines you no longer use. These measures will help protect the environment.

If the medicine becomes discolored or shows any other signs of deterioration, you should seek the advice of your pharmacist who will tell you what to do.

### 6. Contents of the pack and other information

#### What Aranesp contains

- The active substance is darbepoetin alfa, r-HuEPO (erythropoietin produced by gene-technology). The pre-filled syringe contains 300 micrograms of darbepoetin alfa.
- The other ingredients are sodium phosphate monobasic, sodium phosphate dibasic, sodium chloride, polysorbate 80 and water for injections.

#### What Aranesp looks like and contents of the pack

Aranesp is a clear, colourless or slightly pearly solution for injection in a pre-filled syringe.

Aranesp is available in pack of 1 pre-filled syringe with automatic needle guard in a blister wrapping.

**Manufacturer**  
Amgen Europe B.V.  
Minervum 7061  
4817 ZK Breda  
Netherlands

or

Amgen Technology (Ireland)  
Unlimited Company  
Pottery Road  
Dun Laoghaire  
Co Dublin

or

Amgen NV  
Telecomlaan 5-7  
1831 Diegem  
Belgium

**Procured from within the EU and repackaged for the PL Holder:** Abacus Medicine Ltd., Abbey House, 282 Farnborough Road, Farnborough, GU14 7NA, United Kingdom

PL 45763/1045

Aranesp® is a registered trademark of Amgen Inc.

For any information about this medicine, please contact the local representative of the Product Licence Holder: Abacus Medicine Ltd.  
tel: tel: +44(0)2036301244  
email: [MedInfo@abacusmedicine.co.uk](mailto:MedInfo@abacusmedicine.co.uk) or [drugsafetyuk@abacusmedicine.co.uk](mailto:drugsafetyuk@abacusmedicine.co.uk)

**This leaflet was last revised on 22.08.2025.**

**Blind or partially sighted?  
Is this leaflet hard to see or read?  
Call 02036301310 or write to [info@abacusmedicine.com](mailto:info@abacusmedicine.com) to obtain the leaflet in a format suitable for you.**

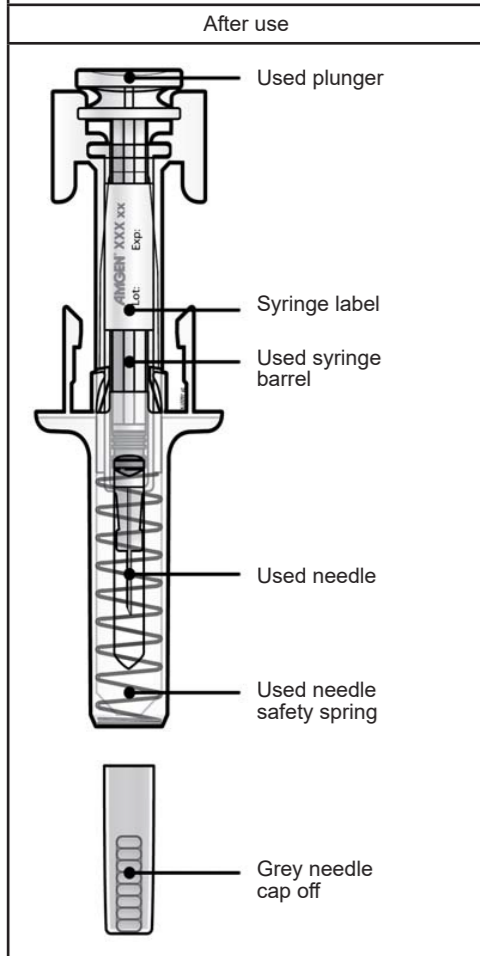
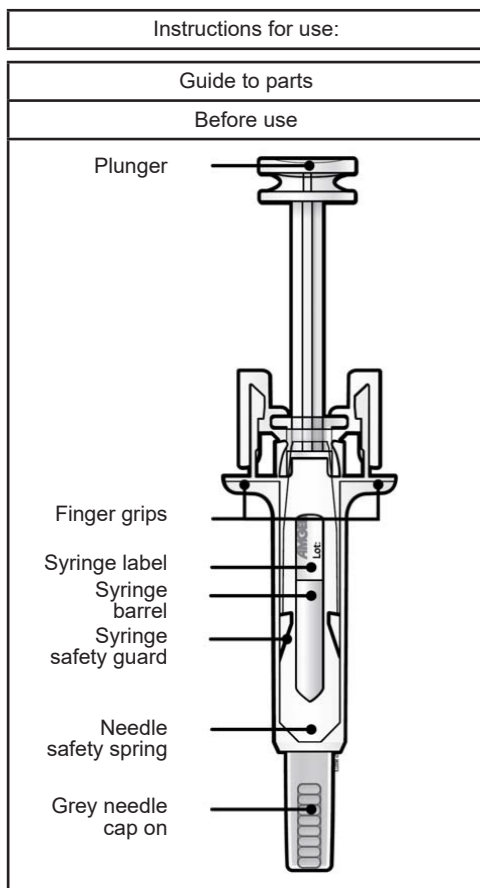

**Important**

**Before you use an Aranesp pre-filled syringe with automatic needle guard, read this important information:**

- It is important that you do not try to give yourself the injection unless you have received training from your doctor or healthcare provider.
- Aranesp is given as an injection into the tissue just under the skin (subcutaneous injection).
- Tell your doctor if you have an allergy to latex. The needle cap on the pre-filled syringe contains a derivative of latex and may cause severe allergic reactions.

**Do not** remove the grey needle cap from the pre-filled syringe until you are ready to inject.

**Do not** use the pre-filled syringe if it has been dropped on a hard surface. Use a new pre-filled syringe and call your doctor or healthcare provider.

**Do not** attempt to activate the pre-filled syringe prior to injection.

**Do not** attempt to remove the clear pre-filled syringe safety guard from the pre-filled syringe.

**Do not** attempt to remove the peelable label on the pre-filled syringe barrel before administering your injection.

Call your doctor or healthcare provider if you have any questions.

**Step 1: Prepare**

**A** Remove the pre-filled syringe tray from the package and gather the supplies needed for your injection: alcohol wipes, a cotton ball or gauze pad, a plaster and a sharps disposal container (not included).

Put the original package with any unused pre-filled syringes back in the refrigerator.

For a more comfortable injection, leave the pre-filled syringe at room temperature for about 30 minutes before injecting. Wash your hands thoroughly with soap and water.

On a clean, well-lit work surface, place the new pre-filled syringe and the other supplies.

- Do not** try to warm the syringe by using a heat source such as hot water or microwave
- Do not** leave the pre-filled syringe exposed to direct sunlight
- Do not** shake the pre-filled syringe

**Keep pre-filled syringes out of the sight and reach of children**

**B** Open the tray, peeling away the cover. Grab the pre-filled syringe safety guard to remove the pre-filled syringe from the tray.

**Grab here**

For safety reasons:

- Do not** grasp the plunger
- Do not** grasp the grey needle cap

**C** Inspect the medicine and pre-filled syringe.

Medicine

**Do not** use the pre-filled syringe if:

- The medicine is cloudy or there are particles in it. It must be a clear and colourless liquid.
- Any part appears cracked or broken.
- The grey needle cap is missing or not securely attached.
- The expiry date printed on the label has passed the last day of the month shown.

In all cases, call your doctor or healthcare provider.

**Step 2: Get ready**

**A** Wash your hands thoroughly. Prepare and clean your injection site.

Upper arm

Belly

Upper thigh

**You can use:**

- Upper part of your thigh
- Belly, except for a 5 cm (2-inch) area right around your belly button
- Outer area of upper arm (only if someone else is giving you the injection)

Clean the injection site with an alcohol wipe. Let your skin dry.

- Do not** touch the injection site before injecting

**!** Choose a different site each time you give yourself an injection. If you need to use the same injection site, just make sure it is not the same spot on that site you used last time. **Do not** inject into areas where the skin is tender, bruised, red, or hard. Avoid injecting into areas with scars or stretch marks.

**B** Carefully pull the grey needle cap straight out and away from your body.

**C** Pinch your injection site to create a firm surface.

**!** It is important to keep the skin pinched when injecting.

**Step 3: Inject**

**A** Hold the pinch. INSERT the needle into skin.

**Do not** touch the cleaned area of the skin

**B** PUSH the plunger with slow and constant pressure until you feel or hear a "snap". Push all the way down through the snap.

**!** It is important to push down through the "snap" to deliver your full dose.

**C** RELEASE your thumb. Then LIFT the syringe off skin.

After releasing the plunger, the pre-filled syringe safety guard will safely cover the injection needle.

- Do not** put the grey needle cap back on used pre-filled syringes.

**Healthcare Providers only**

Remove and save the pre-filled syringe label.

Turn the plunger to move the label into a position where you can remove the syringe label.

**Step 4: Finish**

**A** Discard the used pre-filled syringe and other supplies in a sharps disposal container.

Medicines should be disposed of in accordance with local requirements. Ask your pharmacist how to dispose of medicines no longer required. These measures will help to protect the environment.

- Do not** reuse the pre-filled syringe
- Do not** recycle pre-filled syringes or throw them into household waste

**B** Examine the injection site.

If there is blood, press a cotton ball or gauze pad on your injection site. **Do not** rub the injection site. Apply a plaster if needed.