

## **SUMMARY OF PRODUCT CHARACTERISTICS**

▼ This medicinal product is subject to additional monitoring. This will allow quick identification of new safety information. Healthcare professionals are asked to report any suspected adverse reactions. See section 4.8 for how to report adverse reactions.

### **1 NAME OF THE MEDICINAL PRODUCT**

Topiramate Rosemont 20mg/ml Oral Suspension

### **2 QUALITATIVE AND QUANTITATIVE COMPOSITION**

Each 1ml contains 20mg topiramate.

Excipient(s) with known effect:

Sodium methyl hydroxybenzoate (E219) 1.51 mg/ml

Sodium ethyl hydroxybenzoate (E215) 0.75 mg/ml

Glycerol (E422) 400 mg/ml

Benzoic acid (E210) 0.001mg/ml

Sodium 4.26 mg/ml

For a full list of excipients, see section 6.1

### **3 PHARMACEUTICAL FORM**

Oral Suspension

Colourless or off-white suspension

### **4 CLINICAL PARTICULARS**

#### **4.1 Therapeutic indications**

Monotherapy in adults, adolescents and children over 6 years of age with partial seizures with or without secondary generalised seizures, and primary generalised tonic-clonic seizures.

Adjunctive therapy in children aged 2 years and above, adolescents and adults with partial onset seizures with or without secondary generalization or primary generalized tonic-clonic seizures and for the treatment of seizures associated with Lennox-Gastaut syndrome.

Topiramate is indicated in adults for the prophylaxis of migraine headache after careful evaluation of possible alternative treatment options. Topiramate is not intended for acute treatment.

## 4.2 Posology and method of administration

### Posology

If low doses are required, the 10mg/ml strength product is the most suitable presentation.

If high doses are required, the 20mg/ml strength product is the most suitable presentation.

It is recommended that therapy be initiated at a low dose followed by titration to an effective dose. Dose and titration rate should be guided by clinical response.

It is not necessary to monitor topiramate plasma concentrations to optimize therapy with topiramate. On rare occasions, the addition of topiramate to phenytoin may require an adjustment of the dose of phenytoin to achieve optimal clinical outcome. Addition or withdrawal of phenytoin and carbamazepine to adjunctive therapy with topiramate may require adjustment of the dose of topiramate.

In patients with or without a history of seizures or epilepsy, antiepileptic drugs (AEDs) including topiramate should be gradually withdrawn to minimize the potential for seizures or increased seizure frequency. In clinical trials, daily dosages were decreased in weekly intervals by 50-100 mg in adults with epilepsy and by 25-50 mg in adults receiving topiramate at doses up to 100 mg/day for migraine prophylaxis. In paediatric clinical trials, topiramate was gradually withdrawn over a 2-8 week period.

### Monotherapy epilepsy

#### *General*

When concomitant AEDs are withdrawn to achieve monotherapy with topiramate, consideration should be given to the effects this may have on seizure control. Unless safety concerns require an abrupt withdrawal of the concomitant AED, a gradual discontinuation at the rate of approximately one-third of the concomitant AED dose every 2 weeks is recommended.

When enzyme inducing medicinal products are withdrawn, topiramate levels will increase. A decrease in topiramate dosage may be required if clinically indicated.

#### *Adults*

Dose and titration should be guided by clinical response. Titration should begin at 25 mg nightly for 1 week. The dosage should then be increased at 1- or 2-week intervals by increments of 25 or 50 mg/day, administered in two divided doses. If the patient is unable to tolerate the titration regimen, smaller increments or longer intervals between increments can be used.

The recommended initial target dose for topiramate monotherapy in adults is 100 mg/day to 200 mg/day in 2 divided doses. The maximum recommended daily dose is 500 mg/day in 2 divided doses. Some patients with refractory forms of epilepsy have tolerated topiramate monotherapy at doses of 1,000 mg/day. These dosing recommendations apply to all adults including the elderly in the absence of underlying renal disease.

#### *Paediatric population (children over 6 years of age)*

Dose and titration rate in children should be guided by clinical outcome. Treatment of children over 6 years of age should begin at 0.5 to 1 mg/kg nightly for the first week.

The dosage should then be increased at 1 or 2 week intervals by increments of 0.5 to 1 mg/kg/day, administered in two divided doses. If the child is unable to tolerate the titration regimen, smaller increments or longer intervals between dose increments can be used.

The recommended initial target dose range for topiramate monotherapy in children over 6 years of age is 100 mg/day depending on clinical response, (this is about 2.0 mg/kg/day in children 6-16 years).

Adjunctive therapy epilepsy (partial onset seizures with or without secondary generalization, primary generalized tonic-clonic seizures, or seizures associated with Lennox-Gastaut syndrome).

#### *Adults*

Therapy should begin at 25-50 mg nightly for one week. Use of lower initial doses has been reported, but has not been studied systematically. Subsequently, at weekly or bi-weekly intervals, the dose should be increased by 25-50 mg/day and taken in two divided doses. Some patients may achieve efficacy with once-a-day dosing.

In clinical trials as adjunctive therapy, 200 mg was the lowest effective dose. The usual daily dose is 200-400 mg in two divided doses.

These dosing recommendations apply to all adults, including the elderly, in the absence of underlying renal disease (see section 4.4).

#### *Paediatric population (children aged 2 years and above)*

The recommended total daily dose of topiramate as adjunctive therapy is approximately 5 to 9 mg/kg/day in two divided doses. Titration should begin at 25 mg (or less, based on a range of 1 to 3 mg/kg/day) nightly for the first week. The dosage should then be increased at 1- or 2-week intervals by increments of 1 to 3 mg/kg/day (administered in two divided doses), to achieve optimal clinical response.

Daily doses up to 30 mg/kg/day have been studied and were generally well tolerated.

#### Migraine

### *Adults*

The recommended total daily dose of topiramate for prophylaxis of migraine headache is 100 mg/day administered in two divided doses. Titration should begin at 25 mg nightly for 1 week. The dosage should then be increased in increments of 25 mg/day administered at 1-week intervals. If the patient is unable to tolerate the titration regimen, longer intervals between dose adjustments can be used.

Some patients may experience a benefit at a total daily dose of 50 mg/day. Patients have received a total daily dose up to 200 mg/day. This dose may be benefit in some patients, nevertheless, caution is advised due to an increase incidence of side effects.

### *Paediatric population*

Topiramate is not recommended for treatment or prevention of migraine in children due to insufficient data on safety and efficacy.

### General dosing recommendations for topiramate in special patient populations

#### *Renal impairment*

In patients with impaired renal function ( $CL_{CR} \leq 70$  mL/min) topiramate should be administered with caution as the plasma and renal clearance of topiramate are decreased. Subjects with known renal impairment may require a longer time to reach steady-state at each dose. Half of the usual starting and maintenance dose is recommended (see section 5.2).

In patients with end-stage renal failure, since topiramate is removed from plasma by haemodialysis, a supplemental dose of topiramate equal to approximately one-half the daily dose should be administered on haemodialysis days. The supplemental dose should be administered in divided doses at the beginning and completion of the haemodialysis procedure. The supplemental dose may differ based on the characteristics of the dialysis equipment being used (see section 5.2).

#### *Hepatic impairment*

In patients with moderate to severe hepatic impairment topiramate should be administered with caution as the clearance of topiramate is decreased.

#### *Elderly*

No dose adjustment is required in the elderly population providing renal function is intact.

### Method of administration

For oral administration. The oral suspension is particularly recommended for children and adults with swallowing difficulties, as it allows a secure and precise dosage.

Please shake the bottle thoroughly before use.

Topiramate can be taken without regard to meals.

For instructions on how to use the devices, refer to section 6.6.

*Dosage equivalence for the syringe*

Each 0.25 ml = 5 mg

Each 0.5 ml = 10 mg

Measured Amount (ml)	Amount of topiramate (mg)
1 ml	20 mg
1.25 ml	25 mg
2 ml	40 mg
2.5 ml	50 mg
3 ml	60 mg
3.75 ml	75 mg
4 ml	80 mg
5 ml	100 mg

### **4.3 Contraindications**

Hypersensitivity to the active substance or to any of the excipients listed in section 6.1.

*Prophylaxis of migraine*

- in pregnancy (see sections 4.4 and 4.6).
- in women of childbearing potential unless the conditions of the Pregnancy Prevention Programme are fulfilled (see sections 4.4, 4.5 and 4.6).

*Epilepsy*

- in pregnancy unless there is no suitable alternative (see sections 4.4 and 4.6).
- in women of childbearing potential unless the conditions of the Pregnancy Prevention Programme are fulfilled (see sections 4.4, 4.5 and 4.6).

### **4.4 Special warnings and precautions for use**

In situations where rapid withdrawal of topiramate is medically required, appropriate monitoring is recommended (see section 4.2).

As with other AEDs, some patients may experience an increase in seizure frequency or the onset of new types of seizures with topiramate. These phenomena may be the consequence of an overdose, a decrease in plasma concentrations of concomitantly used AEDs, progress of the disease, or a paradoxical effect.

Adequate hydration while using topiramate is very important. Hydration can reduce the risk of nephrolithiasis (see below). Proper hydration prior to and during activities such as exercise or exposure to warm temperatures may reduce the risk of heat related adverse reactions (see section 4.8).

### Pregnancy prevention programme

Topiramate can cause major congenital malformations and fetal growth restriction when administered to a pregnant woman.

Some data suggest an increased risk of neurodevelopmental disorders in children exposed to topiramate in utero, while other data do not suggest an increased risk (see section 4.6).

Topiramate is contraindicated in women of childbearing potential unless the conditions of the Pregnancy Prevention Programme are fulfilled (see section 4.3 and 4.6)

The conditions of the Pregnancy Prevention Programme are that the prescriber must ensure that:

- Individual circumstances should be evaluated in each case. Involving the patient in the discussion to support her engagement, discuss therapeutic options and ensure her understanding of the risks and the measures needed to minimise the risks.
- The potential for pregnancy is assessed for all female patients.
- The patient has understood and acknowledged the risks of congenital malformations, neurodevelopmental disorders and fetal growth restriction in children exposed to topiramate *in utero*.
- The patient understands the need to undergo pregnancy testing prior to initiation of topiramate and during treatment, as needed.
- The patient is counselled regarding contraception, and that the patient is capable of complying with the need to use effective contraception without interruption during the entire duration of treatment with topiramate and for at least 4 weeks after stopping treatment.
- The patient understands the need for regular (at least annual) review of treatment.
- The patient understands the need to consult her physician as soon as she is planning pregnancy to ensure timely discussion and switching to alternative treatment options prior to conception and before contraception is discontinued.
- The patient understands the need to urgently consult her physician in case of pregnancy.
- The patient has received the Patient Guide.
- The patient has acknowledged that she has understood the hazards and necessary precautions associated with topiramate use (Annual Risk Awareness Form).

These conditions also concern women who are not currently sexually active unless the prescriber considers that there are compelling reasons to indicate that there is no risk of pregnancy.

### Women of childbearing potential

Pregnancy testing should be performed before initiating treatment with topiramate in a woman of childbearing potential.

The patient must be fully informed and understand the risks related to the use of topiramate during pregnancy (see sections 4.3 and 4.6). This includes the need to consult her doctor if the woman is planning a pregnancy to discuss switching to alternative treatments prior to discontinuation of

contraception, and for prompt contact with a doctor if she becomes pregnant or thinks she may be pregnant.

This includes the need to consult her doctor as soon as she is planning for pregnancy and for prompt contact with her doctor if she becomes pregnant or thinks she may be pregnant and is taking topiramate.

#### Female children

Prescribers must ensure that parent(s)/caregiver(s) of female children using topiramate understand the need to contact a specialist once the female child experiences menarche. At that time, the patient and parent(s)/caregiver(s) should be provided with comprehensive information about the risks due to topiramate exposure in utero and the need for using highly effective contraception as soon as relevant. The need for continued topiramate therapy should be reassessed and alternative treatment options should also be considered.

Educational materials regarding these measures are available for healthcare professionals and patients (or parents/caregivers). The patient guide must be provided to all women of childbearing potential using topiramate and to parents/ caregivers of female children. A patient card is provided with the package of topiramate.

#### Oligohydrosis

Oligohydrosis (decreased sweating) has been reported in association with the use of topiramate. Decreased sweating and hyperthermia (rise in body temperature) may occur especially in young children exposed to high ambient temperature.

#### Mood disturbances/depression

An increased incidence of mood disturbances and depression has been observed during topiramate treatment.

#### Suicide/suicide ideation

Suicidal ideation and behaviour have been reported in patients treated with antiepileptic agents in several indications. A meta-analysis of randomised placebo controlled trials of AEDs has shown a small increased risk of suicidal ideation and behaviour. The mechanism of this risk is not known and the available data do not exclude the possibility of an increased risk for topiramate.

In double blind clinical trials, suicide related events (SREs) (suicidal ideation, suicide attempts and suicide) occurred at a frequency of 0.5% in topiramate treated patients (46 out of 8,652 patients treated) and at a nearly 3 fold higher incidence than those treated with placebo (0.2%; 8 out of 4,045 patients treated).

Patients therefore should be monitored for signs of suicidal ideation and behaviour and appropriate treatment should be considered. Patients (and caregivers of patients) should be advised to seek medical advice should signs of suicidal ideation or behaviour emerge.

#### Serious skin reactions

Serious skin reactions (Stevens-Johnson Syndrome (SJS) and Toxic Epidermal Necrolysis (TEN)) have been reported in patients receiving topiramate (see section 4.8). It is recommended that patients be informed about the signs of serious skin reactions. If SJS or TEN are suspected, use of topiramate should be discontinued.

#### Nephrolithiasis

Some patients, especially those with a predisposition to nephrolithiasis, may be at increased risk for renal stone formation and associated signs and symptoms such as renal colic, renal pain or flank pain.

Risk factors for nephrolithiasis include prior stone formation, a family history of nephrolithiasis and hypercalciuria. None of these risk factors can reliably predict stone formation during topiramate treatment. In addition, patients taking other medicinal products associated with nephrolithiasis may be at increased risk.

#### Decreased renal function

In patients with impaired renal function (CLCR  $\leq$ 70mL/min) topiramate should be administered with caution as the plasma and renal clearance of topiramate are decreased. For specific posology recommendations in patients with decreased renal function, see section 4.2.

#### Decreased hepatic function

In hepatically impaired patients, topiramate should be administered with caution as the clearance of topiramate may be decreased.

#### Acute myopia and secondary angle closure glaucoma syndrome

A syndrome consisting of acute myopia associated with secondary angle closure glaucoma has been reported in patients receiving topiramate. Symptoms include acute onset of decreased visual acuity and/or ocular pain. Ophthalmologic findings can include myopia, anterior chamber shallowing, ocular hyperaemia (redness), choroidal detachments, retinal pigment epithelial detachments, macular striae, and increased intraocular pressure. Mydriasis may or may not be present. This syndrome may be associated with supraciliary effusion resulting in anterior displacement of the lens and iris, with secondary angle closure glaucoma. Symptoms typically occur within 1 month of initiating topiramate therapy. In contrast to primary narrow angle glaucoma, which is rare under 40 years of age, secondary angle closure glaucoma associated with topiramate has been reported in paediatric patients as well as adults. Treatment includes discontinuation of topiramate, as rapidly as possible in the judgment of the treating physician, and appropriate measures to reduce intraocular pressure. These measures generally result in a decrease in intraocular pressure.

Elevated intraocular pressure of any aetiology, if left untreated, can lead to serious sequelae including permanent vision loss.

A determination should be made whether patients with history of eye disorders should be treated with topiramate.

#### Visual field defects

Visual field defects have been reported in patients receiving topiramate independent of elevated intraocular pressure. In clinical trials, most of these events were reversible after topiramate discontinuation. If visual field defects occur at any time during topiramate treatment, consideration should be given to discontinuing the drug.

#### Metabolic acidosis and sequelae

Hyperchloremic, non-anion gap, metabolic acidosis (i.e. decreased serum bicarbonate below the normal reference range in the absence of respiratory alkalosis) is associated with topiramate treatment. This decrease in serum bicarbonate is due to the inhibitory effect of topiramate on renal carbonic anhydrase. Generally, the decrease in bicarbonate occurs early in treatment although it can occur at any time during treatment. These decreases are usually mild to moderate (average decrease of 4mmol/l at doses of 100mg/day or above in adults and at approximately 6mg/kg/day in paediatric patients). Rarely, patients have experienced decreases to values below 10mmol/l. Conditions or therapies that predispose to acidosis (such as renal disease, severe respiratory disorders, status epilepticus, diarrhoea, surgery, ketogenic diet, or certain medicinal products) may be additive to the bicarbonate lowering effects of topiramate.

Chronic untreated metabolic acidosis increases the risk of nephrolithiasis and nephrocalcinosis and may potentially lead to osteopenia.

Chronic metabolic acidosis in paediatric patients can reduce growth rates. The effect of topiramate on bone related sequelae has not been systematically investigated in adult populations. For paediatric patients aged 6 to 15 years a one year, open-label study was conducted (see section 5.1).

Depending on underlying conditions, appropriate evaluation including serum bicarbonate levels is recommended with topiramate therapy. If signs or symptoms are present (e.g. Kussmaul's deep breathing, dyspnoea, anorexia, nausea, vomiting, excessive tiredness, tachycardia or arrhythmia), indicative of metabolic acidosis, measurement of serum bicarbonate is recommended. If metabolic acidosis develops and persists, consideration should be given to reducing the dose or discontinuing topiramate (using dose tapering). Topiramate should be used with caution in patients with conditions or treatments that represent a risk factor for the appearance of metabolic acidosis.

#### Impairment of cognitive function

Cognitive impairment in epilepsy is multifactorial and may be due to the underlying aetiology, due to the epilepsy or due to the antiepileptic treatment. There have been reports in the literature of impairment of cognitive function in adults on topiramate therapy which required reduction in dosage or discontinuation of treatment. However, studies regarding cognitive outcomes in children treated with topiramate are insufficient and its effect in this regard still needs to be elucidated.

#### Hyperammonemia and encephalopathy

Hyperammonemia with or without encephalopathy has been reported with topiramate treatment (see section 4.8). The risk for hyperammonemia with topiramate appears dose-related. Hyperammonemia has been reported more frequently when topiramate is used concomitantly with valproic acid (see section 4.5).

In patients who develop unexplained lethargy or changes in mental status associated with topiramate monotherapy or adjunctive therapy, it is recommended that consideration be given to the possibility of hyperammonemic encephalopathy and measurement of ammonia levels.

#### Nutritional supplementation

Some patients may experience weight loss whilst on treatment with topiramate. It is recommended that patients on topiramate treatment should be monitored for weight loss. A dietary supplement or increased food intake may be considered if the patient is losing weight while on topiramate.

#### Excipient Warnings

This product contains:

- Sodium methyl hydroxybenzoate (E219) and sodium ethyl hydroxybenzoate (E215), which may cause allergic reactions (possibly delayed).
- Glycerol (E422), which may cause headache, stomach upset and diarrhoea.
- Benzoic acid (E210), which may increase jaundice (yellowing of the skin and eyes) in newborn babies (up to 4 weeks old). This medicine contains 0.001 mg per 1 ml dose.

Sodium. This medicinal product contains 4.26 mg sodium per 1 ml dose, equivalent to 0.2% of the WHO recommended maximum daily intake of 2g sodium for an adult.

## **4.5 Interaction with other medicinal products and other forms of interaction**

#### Effects of topiramate on other antiepileptic medicinal products

The addition of topiramate to other AEDs (phenytoin, carbamazepine, valproic acid, phenobarbital, primidone) has no effect on their steady-state plasma concentrations, except in the occasional patient, where the addition of topiramate to phenytoin may result in an increase of plasma concentrations of phenytoin. This is possibly due to inhibition of a specific enzyme polymorphic isoform (CYP2C19). Consequently, any patient on phenytoin showing clinical signs or symptoms of toxicity should have phenytoin levels monitored.

A pharmacokinetic interaction study of patients with epilepsy indicated the addition of topiramate to lamotrigine had no effect on steady state plasma concentration of lamotrigine at topiramate doses of 100 to 400 mg/day. In addition, there was no change in steady state plasma concentration of topiramate during or after removal of lamotrigine treatment (mean dose of 327 mg/day).

Topiramate inhibits the enzyme CYP 2C19 and may interfere with other substances metabolized via this enzyme (e.g., diazepam, imipramin, moclobemide, proguanil, omeprazol).

#### Effects of other antiepileptic medicinal products on topiramate

Phenytoin and carbamazepine decrease the plasma concentration of topiramate. The addition or withdrawal of phenytoin or carbamazepine to topiramate therapy may require an adjustment in dosage of the latter. This should be done by titrating to clinical effect. The addition or withdrawal of valproic acid does not produce clinically significant changes in plasma concentrations of topiramate and, therefore, does not warrant dosage adjustment of topiramate.

The results of these interactions are summarized below:

AED Co-administered	AED Concentration	Topiramate Concentration
Phenytoin	↔**	↓
Carbamazepine (CBZ)	↔	↓
Valproic acid	↔	↔
Lamotrigine	↔	↔
Phenobarbital	↔	NS
Primidone	↔	NS

↔ = No effect on plasma concentration (≤15% change)

\*\* = Plasma concentrations increase in individual patients

↓ = Plasma concentrations decrease

NS = Not studied

AED = antiepileptic drug

#### Other medicinal product interactions

##### *Digoxin*

In a single-dose study, serum digoxin area under plasma concentration curve (AUC) decreased 12% due to concomitant administration of topiramate. The clinical relevance of this observation has not been established. When topiramate is added or withdrawn in patients on digoxin therapy, careful attention should be given to the routine monitoring of serum digoxin.

##### *Central nervous system depressants*

Concomitant administration of topiramate and alcohol or other central nervous system (CNS) depressant medicinal products has not been evaluated in clinical studies. It is recommended that topiramate not be used concomitantly with alcohol or other CNS depressant medicinal products.

##### *St John's Wort (Hypericum perforatum)*

A risk of decreased plasma concentrations resulting in a loss of efficacy could be observed with co-administration of topiramate and St John's Wort. There have been no clinical studies evaluating this potential interaction.

##### *Systemic hormonal contraceptives*

In a pharmacokinetic interaction study in healthy volunteers with a concomitantly administered combination oral contraceptive product containing 1 mg norethindrone (NET) plus 35 µg ethinyl estradiol (EE), topiramate given in the absence of other medications at doses of 50 to 200 mg/day was not associated with statistically significant changes in mean exposure (AUC) to either component of the oral contraceptive. In another study, exposure to EE was statistically significantly decreased at doses of 200, 400, and 800 mg/day (18%, 21%, and 30%, respectively) when given as adjunctive therapy in epilepsy patients taking valproic acid. In both studies, topiramate (50-200 mg/day in healthy volunteers and 200-800 mg/day in epilepsy patients) did not significantly affect exposure to NET. Although there was a dose dependent decrease in EE exposure for doses between 200-800 mg/day (in epilepsy patients), there was no significant dose dependent change in EE exposure for doses of 50-200 mg/day (in healthy volunteers). The clinical significance of the changes observed is not known. The possibility of decreased contraceptive efficacy and increased breakthrough bleeding should be considered in patients taking systemic contraceptive products with topiramate. Patients should be asked to report any change in their bleeding patterns. Contraceptive efficacy can be decreased even in the absence of breakthrough bleeding. Women using systemic hormonal contraceptives should be advised to also use a barrier method.

#### *Lithium*

In healthy volunteers, there was an observed reduction (18% for AUC) in systemic exposure for lithium during concomitant administration with topiramate 200 mg/day. In patients with bipolar disorder, the pharmacokinetics of lithium were unaffected during treatment with topiramate at doses of 200 mg/day; however, there was an observed increase in systemic exposure (26% for AUC) following topiramate doses of up to 600 mg/day. Lithium levels should be monitored when co-administered with topiramate.

#### *Risperidone*

Drug-drug interaction studies conducted under single dose conditions in healthy volunteers and multiple dose conditions in patients with bipolar disorder, yielded similar results. When administered concomitantly with topiramate at escalating doses of 100, 250 and 400 mg/day there was a reduction in risperidone (administered at doses ranging from 1 to 6 mg/day) systemic exposure (16% and 33% for steady-state AUC at the 250 and 400 mg/day doses, respectively). However, differences in AUC for the total active moiety between treatment with risperidone alone and combination treatment with topiramate were not statistically significant. Minimal alterations in the pharmacokinetics of the total active moiety (risperidone plus 9-hydroxyrisperidone) and no alterations for 9-hydroxyrisperidone were observed. There were no significant changes in the systemic exposure of the risperidone total active moiety or of topiramate. When topiramate was added to existing risperidone (1-6 mg/day) treatment, adverse events were reported more frequently than prior to topiramate (250-400 mg/day) introduction (90% and 54% respectively). The most frequently reported AE's when topiramate was added to risperidone treatment were: somnolence (27% and 12%), paraesthesia (22% and 0%) and nausea (18% and 9% respectively).

#### *Hydrochlorothiazide (HCTZ)*

A drug-drug interaction study conducted in healthy volunteers evaluated the steady-state pharmacokinetics of HCTZ (25 mg every 24h) and topiramate (96 mg every 12h) when administered alone and concomitantly. The results of this study indicate that topiramate  $C_{max}$  increased by 27% and AUC increased by 29% when HCTZ was added to topiramate. The clinical significance of this change is unknown. The addition of HCTZ to topiramate therapy may require an adjustment of the topiramate dose. The steady-state pharmacokinetics of HCTZ were not significantly influenced by the concomitant administration of topiramate.

Clinical laboratory results indicated decreases in serum potassium after topiramate or HCTZ administration, which were greater when HCTZ and topiramate were administered in combination.

#### *Metformin*

A drug-drug interaction study conducted in healthy volunteers evaluated the steady-state pharmacokinetics of metformin and topiramate in plasma when metformin was given alone and when metformin and topiramate were given simultaneously. The results of this study indicated that metformin mean  $C_{max}$  and mean  $AUC_{0-12h}$  increased by 18% and 25%, respectively, while mean  $CL/F$  decreased 20% when metformin was co-administered with topiramate. Topiramate did not affect metformin  $t_{max}$ . The clinical significance of the effect of topiramate on metformin pharmacokinetics is unclear. Oral plasma clearance of topiramate appears to be reduced when administered with metformin. The extent of change in the clearance is unknown. The clinical significance of the effect of metformin on topiramate pharmacokinetics is unclear.

When topiramate is added or withdrawn in patients on metformin therapy, careful attention should be given to the routine monitoring for adequate control of their diabetic disease state.

#### *Pioglitazone*

A drug-drug interaction study conducted in healthy volunteers evaluated the steady-state pharmacokinetics of topiramate and pioglitazone when administered alone and concomitantly. A 15% decrease in the  $AUC_{\tau,ss}$  of pioglitazone with no alteration in  $C_{max,ss}$  was observed. This finding was not statistically significant. In addition, a 13% and 16% decrease in  $C_{max,ss}$  and  $AUC_{\tau,ss}$  respectively, of the active hydroxy-metabolite was noted as well as a 60% decrease in  $C_{max,ss}$  and  $AUC_{\tau,ss}$  of the active keto-metabolite. The clinical significance of these findings is not known. When topiramate is added to pioglitazone therapy or pioglitazone is added to topiramate therapy, careful attention should be given to the routine monitoring of patients for adequate control of their diabetic disease state.

#### *Glibenclamide*

A drug-drug interaction study conducted in patients with type 2 diabetes evaluated the steady state pharmacokinetics of glibenclamide (5 mg/day) alone and concomitantly with topiramate (150 mg/day). There was a 25% reduction in glibenclamide  $AUC_{24}$  during topiramate administration. Systemic exposure of the active metabolites, 4-*trans*-hydroxy-glyburide (M1) and 3-*cis*-hydroxyglyburide (M2), were also reduced by 13% and 15%, respectively. The steady-state pharmacokinetics of topiramate were unaffected by concomitant administration of glibenclamide. When topiramate is added to glibenclamide therapy or glibenclamide is added to topiramate therapy, careful attention should be given to the routine monitoring of patients for adequate control of their diabetic disease state.

#### Other forms of interactions

##### *Agents predisposing to nephrolithiasis*

Topiramate, when used concomitantly with other agents predisposing to nephrolithiasis, may increase the risk of nephrolithiasis. While using topiramate, agents like these should be avoided since they may create a physiological environment that increases the risk of renal stone formation.

##### *Valproic acid*

Concomitant administration of topiramate and valproic acid has been associated with hyperammonemia with or without encephalopathy in patients who have tolerated either medicinal product alone. In most cases, symptoms and signs abated with discontinuation of either medicinal product. This adverse reaction is not due to a pharmacokinetic interaction.

Hypothermia, defined as an unintentional drop in body core temperature to  $<35^{\circ}C$ , has been reported in association with concomitant use of topiramate and valproic acid (VPA) both in conjunction with hyperammonemia and in the absence of hyperammonemia. This adverse event in patients using concomitant topiramate and valproate can occur after starting topiramate treatment or after increasing the daily dose of topiramate.

### Warfarin

Decreased Prothrombin Time/International Normalized Ratio (PT/INR) has been reported in patients treated with topiramate in combination with warfarin. Therefore, INR should be carefully monitored in patients concomitantly treated with topiramate and warfarin.

### Additional pharmacokinetic drug interaction studies

Clinical studies have been conducted to assess the potential pharmacokinetic drug interaction between topiramate and other agents. The changes in  $C_{max}$  or AUC as a result of the interactions are summarized below. The second column (concomitant drug concentration) describes what happens to the concentration of the concomitant drug listed in the first column

when topiramate is added. The third column (topiramate concentration) describes how the co-administration of a drug listed in the first column modifies the concentration of topiramate.

<b>Summary of Results from Additional Clinical Pharmacokinetic Drug Interaction Studies</b>		
<b>Concomitant Drug</b>	<b>Concomitant Drug Concentration<sup>a</sup></b>	<b>Topiramate Concentration<sup>a</sup></b>
Amitriptyline	↔ 20% increase in $C_{max}$ and AUC of nortriptyline metabolite	NS
Dihydroergotamine (Oral and Subcutaneous)	↔	↔
Haloperidol	↔ 31% increase in AUC of the reduced metabolite	NS
Propranolol	↔ 17% increase in $C_{max}$ for 4-OH propranolol (TPM 50 mg q12h)	9% and 16% increase in $C_{max}$ , 9% and 17% increase in AUC (40 and 80 mg propranolol q12h respectively)
Sumatriptan (Oral and Subcutaneous)	↔	NS
Pizotifen	↔	↔
Diltiazem	25% decrease in AUC of diltiazem and 18% decrease in DEA, and ↔ for DEM*	20% increase in AUC
Venlafaxine	↔	↔
Flunarizine	16% increase in AUC (TPM 50 mg q12h) <sup>b</sup>	↔

<sup>a</sup> = % values are the changes in treatment mean  $C_{max}$  or AUC with respect to monotherapy

↔ = No effect on  $C_{max}$  and AUC ( $\leq 15\%$  change) of the parent compound

NS = Not studied

\*DEA = des acetyl diltiazem, DEM = N-demethyl diltiazem

<sup>b</sup> = Flunarizine AUC increased 14% in subjects taking flunarizine alone. Increase in exposure may be attributed to accumulation during achievement of steady state.

## 4.6 Fertility, pregnancy and lactation

## Pregnancy

### *Risk related to epilepsy and anti-epileptic drugs (AEDs) in general*

Specialist advice regarding the potential risks to a fetus caused by both seizures and antiepileptic treatment should be given to women of childbearing potential and especially to women planning for pregnancy and women who are pregnant. The need for treatment with AEDs should be reviewed when a woman is planning to become pregnant. In women being treated for epilepsy, sudden discontinuation of AED therapy should be avoided as this may lead to breakthrough seizures that could have serious consequences for the woman and the fetus. Monotherapy should be preferred whenever possible because therapy with multiple AEDs could be associated with a higher risk of congenital malformations than monotherapy, depending on the associated antiepileptics.

### *Risk related to topiramate*

Topiramate is teratogenic in mice, rats and rabbits (see section 5.3). In rats, topiramate crosses the placental barrier.

In humans, topiramate crosses the placenta and similar concentrations have been reported in the umbilical cord and maternal blood.

Clinical data from pregnancy registries indicate that infants exposed in utero to topiramate monotherapy have:

#### Major congenital malformation and fetal growth restriction

- An increased risk of congenital malformations (particularly cleft lip/palate, hypospadias, and anomalies involving various body systems) following exposure during the first trimester. The North American Antiepileptic Drug pregnancy registry data for topiramate monotherapy showed an approximate 3-fold higher prevalence of major congenital malformations (4.3%), compared with a reference group not taking AEDs (1.4%). Data from an observational population-based registry study from the Nordic countries showed a 2 to 3 fold higher prevalence of major congenital malformations (up to 9.5%) compared with a reference group not taking AEDs (3.0%). In addition, data from other studies indicate that, compared with monotherapy, there is an increased risk of teratogenic effects associated with the use of AEDs in combination therapy. The risk has been reported to be dose dependent; effects were observed in all doses. In women treated with topiramate who have had a child with a congenital malformation, there appears to be an increased risk of malformations in subsequent pregnancies when exposed to topiramate.
- A higher prevalence of low birth weight (<2500 grams) compared with a reference group.
- An increased prevalence of being small for gestational age (SGA; defined as birth weight below the 10th percentile corrected for their gestational age, stratified by sex). In the North American Antiepileptic Drug Pregnancy Registry, the risk of SGA in children of women receiving topiramate was 18 % compared with 5 % in children of women with epilepsy not receiving an AED. The long-term consequences of the SGA findings could not be determined.

#### Neurodevelopmental disorders

- Data from two observational population- based pregnancy registry studies in largely the same dataset from the Nordic countries suggest there may be a 2 to 3-fold higher prevalence of autism spectrum disorders, intellectual disability or attention deficit hyperactivity disorder (ADHD) in almost 300 children of mothers with epilepsy exposed to topiramate in utero, compared with children of mothers with epilepsy not exposed to an AED. A third observational cohort study from the U.S.A. did not suggest an increased cumulative incidence of these outcomes by 8 years of age in approximately 1000 children of mothers with epilepsy exposed to topiramate in utero, compared with children of mothers with epilepsy not exposed to an AED.

#### *Indication epilepsy*

- Topiramate is contraindicated in pregnancy unless there is no suitable alternative treatment (see sections 4.3 and 4.4).
- The woman must be fully informed of and understand risks of using topiramate during pregnancy. This includes discussion about the risks of uncontrolled epilepsy to the pregnancy.
- If a woman is planning to become pregnant, efforts should be made to switch to appropriate alternative treatment before contraception is discontinued.
- If a woman becomes pregnant while taking topiramate, she should promptly be referred to a specialist to reassess topiramate treatment and consider alternative treatment options.
- If topiramate is used during pregnancy, the patient should be referred to a specialist for evaluation and counselling regarding the exposed pregnancy. Careful prenatal monitoring should be performed.

#### *Indication migraine prophylaxis*

Topiramate is contraindicated in pregnancy (see sections 4.3 and 4.4).

#### *Women of childbearing potential (all indications)*

Topiramate is contraindicated in women of childbearing potential unless the conditions of the Pregnancy Prevention Programme are fulfilled (see sections 4.4, 4.5 and 4.6).

At least one highly effective method of contraception (such as intra-uterine device) or two complementary forms of contraception including a barrier method should be used (see sections 4.4 and 4.5) during treatment and for at least 4 weeks after stopping treatment with topiramate.

Alternative therapeutic options should be considered in women of childbearing potential.

Pregnancy testing should be performed before initiating treatment with topiramate in a woman of childbearing potential.

The patient must be fully informed and understand the risks related to the use of topiramate during pregnancy. This includes the need to consult her doctor as soon as she is planning for pregnancy, and for prompt contact with her doctor if she becomes pregnant or thinks she may be pregnant and is taking topiramate.

For women with epilepsy, the risks of uncontrolled epilepsy to the pregnancy should also be taken into account (see sections 4.3 and 4.4).

For female children (see section 4.4).

#### Breast-feeding

Animal studies have shown excretion of topiramate in milk. The excretion of topiramate in human milk has not been evaluated in controlled studies. Limited observations in patients suggest an extensive excretion of topiramate into breast milk. Effects that have been observed in breastfed newborns/infants of treated mothers, include diarrhea, drowsiness, irritability and inadequate weight gain. Therefore, a decision must be made whether to suspend breast-feeding or to discontinue/ abstain from topiramate therapy taking into account the importance of the medicinal product to the mother (see section 4.4).

#### Fertility

Animal studies did not reveal impairment of fertility by topiramate (see section 5.3). The effect of topiramate on human fertility has not been established.

### 4.7 Effects on ability to drive and use machines

Topiramate has minor or moderate influence on the ability to drive and use machines. Topiramate acts on the central nervous system and may produce drowsiness, dizziness or other related symptoms. It may also cause visual disturbances and/or blurred vision. These adverse reactions could potentially be dangerous in patients driving a vehicle or operating machinery, particularly until such time as the individual patient's experience with the medicinal products established.

### 4.8 Undesirable effects

The safety of topiramate was evaluated from a clinical trial database consisting of 4,111 patients (3,182 on topiramate and 929 on placebo) who participated in 20 double-blind trials and 2,847 patients who participated in 34 open-label trials, respectively, for topiramate as adjunctive treatment of primary generalized tonic-clonic seizures, partial onset seizures, seizures associated with Lennox-Gastaut syndrome, monotherapy for newly or recently diagnosed epilepsy or migraine prophylaxis. The majority of adverse reactions were mild to moderate in severity.

Adverse reactions identified in clinical trials, and during post-marketing experience (as indicated by “\*\*”) are listed by their incidence in clinical trials in Table 1.

Assigned frequencies are as follows:

Very common	≥1/10
Common	≥1/100 to <1/10
Uncommon	≥1/1,000 to <1/100
Rare	≥1/10,000 to <1/1,000
Not known	cannot be estimated from the available data

The most common adverse reactions (those with an incidence of >5% and greater than that observed in placebo in at least 1 indication in double-blind controlled studies with topiramate) include: anorexia, decreased appetite, bradyphrenia, depression, expressive language disorder, insomnia, coordination abnormal, disturbance in attention, dizziness, dysarthria, dysgeusia, hypoesthesia, lethargy, memory impairment, nystagmus, paresthesia, somnolence, tremor, diplopia, vision blurred, diarrhoea, nausea, fatigue, irritability, and weight decreased.

<b>Table 1: Topiramate Adverse Reactions</b>					
System Organ	Very common	Common	Uncommon	Rare	Not known

Class					
Infections and infestations	Nasopharyngitis*				
Blood and Lymphatic system disorders		Anaemia	Leucopenia, thrombocytopenia lymphadenopathy, eosinophilia	Neutropenia*	
Immune system disorders		Hypersensitivity			Allergic oedema*
Metabolism and Nutrition disorders		Anorexia, decreased appetite	Metabolic acidosis, hypokalaemia, increased appetite, polydipsia	Acidosis Hyperchloraemic, hyperammonemia*, hyperammonemic encephalopathy*	
Psychiatric disorders	Depression	Bradyphrenia, insomnia, expressive language disorder, anxiety, confusional state, disorientation, aggression, mood altered, agitation, mood swings, depressed mood, anger, abnormal behaviour	Suicidal ideation, suicide attempt, hallucination, psychotic disorder, hallucination auditory, hallucination visual, apathy, lack of spontaneous speech, sleep disorder, affect lability, libido decreased, restlessness, crying, dysphemia, euphoric mood, paranoia, perseveration, panic attack, tearfulness, reading disorder, initial insomnia, flat affect, thinking abnormal, loss of libido, listless, middle insomnia, distractibility, early morning awakening, panic reaction, elevated mood	Mania, panic disorder, feeling of despair*, hypomania	
Nervous system disorders	Paraesthesia, somnolence Dizziness	Disturbance in attention, memory impairment,	Depressed level of consciousness, grand mal	Apraxia, circadian rhythm sleep disorder, hyperaesthesia,	

		<p>amnesia, cognitive disorder, mental impairment, psychomotor skills impaired, convulsion, coordination abnormal, tremor, lethargy, hypoaesthesia, nystagmus, dysgeusia, balance disorder, dysarthria, intention tremor, sedation</p>	<p>convulsion, visual field defect, complex partial seizures, speech disorder, psychomotor hyperactivity, syncope, sensory disturbance, drooling, hypersomnia, aphasia, repetitive speech, hypokinesia, dyskinesia, dizziness postural, poor quality sleep, burning sensation, sensory loss, parosmia, cerebellar syndrome, dysaesthesia, hypogeusia, stupor, clumsiness, aura, ageusia, dysgraphia, dysphasia, neuropathy peripheral, presyncope, dystonia, formication</p>	<p>hyposmia, anosmia, essential tremor, akinesia, unresponsive to stimuli</p>	
Eye disorders		<p>Vision blurred, diplopia, visual disturbance</p>	<p>Visual acuity reduced, scotoma, myopia*, abnormal sensation in eye*, dry eye, photophobia, blepharospasm, lacrimation increased, photopsia, mydriasis, presbyopia</p>	<p>Blindness unilateral, blindness transient, glaucoma, accommodation disorder, altered visual depth perception, scintillating scotoma, eyelid oedema*, night blindness, amblyopia</p>	<p>Angle closure glaucoma*, Maculopathy*, eye movement disorder*, conjunctival oedema*, uveitis</p>
Ear and labyrinth disorders		<p>Vertigo, tinnitus, ear pain</p>	<p>Deafness, deafness unilateral, deafness neurosensory, ear discomfort, hearing impaired</p>		

Cardiac disorders			Bradycardia, sinus bradycardia, palpitations		
Vascular disorders			Hypotension, orthostatic hypotension, flushing, hot flush	Raynaud's phenomenon	
Respiratory, thoracic and mediastinal disorders		Dyspnoea, epistaxis, nasal congestion, rhinorrhoea, cough*	Dyspnoea exertional, Paranasal sinus hypersecretion, dysphonia		
Gastrointestinal disorders	Nausea, diarrhoea	Vomiting, constipation, abdominal pain upper, dyspepsia, abdominal pain, dry mouth, stomach discomfort, paraesthesia oral, gastritis, abdominal discomfort	Pancreatitis, flatulence, gastrooesophageal reflux disease, abdominal pain lower, hypoaesthesia oral, gingival bleeding, abdominal distension, epigastric discomfort, abdominal tenderness, salivary hypersecretion, oral pain, breath odour, glossodynia		
Hepatobiliary disorders				Hepatitis, Hepatic failure	
Skin and subcutaneous tissue disorders		Alopecia, rash, pruritus	Anhidrosis, hypoaesthesia facial, urticaria, erythema, pruritus generalised, rash macular, skin discolouration, dermatitis allergic, swelling face	Stevens-Johnson syndrome* erythema multiforme*, skin odour abnormal, periorbital oedema*, urticaria localised	Toxic epidermal necrolysis*
Musculoskeletal and connective tissue disorders		Arthralgia, muscle spasms, myalgia, muscle twitching, muscular weakness, musculoskeletal chest pain	Joint swelling*, musculoskeletal stiffness, flank pain, muscle fatigue	Limb discomfort*	

Renal and urinary disorders		Nephrolithiasis, pollakiuria, dysuria, nephrocalcinosis*	Calculus urinary, urinary incontinence, haematuria, incontinence, micturition urgency, renal colic, renal pain	Calculus ureteric, renal tubular acidosis*	
Reproductive system and breast disorders			Erectile dysfunction, sexual dysfunction		
General disorders and administration site conditions	Fatigue	Pyrexia, asthenia, irritability, gait disturbance, feeling abnormal, malaise	Hyperthermia, thirst, influenza like illness*, sluggishness, peripheral coldness, feeling drunk, feeling jittery	Face oedema	
Investigations	Weight decreased	Weight increased*	Crystal urine present, tandem gait test abnormal, white blood cell count decreased, Increase in liver enzymes	Blood bicarbonate decreased	
Social circumstances			Learning disability		

\* identified as an adverse reaction from post marketing spontaneous reports. Its frequency was calculated based on clinical trial data, or was calculated if the event did not occur in clinical trials.

Congenital malformations and fetal growth restrictions (see section 4.4 and section 4.6).

#### Paediatric population

Adverse reactions reported more frequently ( $\geq 2$ -fold) in children than in adults in double-blind controlled studies include:

- Decreased appetite
- Increased appetite
- Hyperchloraemic acidosis
- Hypokalaemia
- Abnormal behaviour
- Aggression
- Apathy
- Initial insomnia
- Suicidal ideation
- Disturbance in attention
- Lethargy
- Circadian rhythm sleep disorder
- Poor quality sleep
- Lacrimation increased
- Sinus bradycardia

- Feeling abnormal
- Gait disturbance.

Adverse reactions that were reported in children but not in adults in double-blind controlled studies include:

- Eosinophilia
- Psychomotor hyperactivity
- Vertigo
- Vomiting
- Hyperthermia
- Pyrexia
- Learning disability.

#### Reporting of suspected adverse reactions

Reporting suspected adverse reactions after authorisation of the medicinal product is important. It allows continued monitoring of the benefit/risk balance of the medicinal product. Healthcare professionals are asked to report any suspected adverse reactions via Yellow Card Scheme at [www.mhra.gov.uk/yellowcard](http://www.mhra.gov.uk/yellowcard) or search for MHRA Yellow Card in the Google Play or Apple App Store.

## 4.9 Overdose

#### Signs and symptoms

Overdoses of topiramate have been reported. Signs and symptoms included convulsions, drowsiness, speech disturbances, blurred vision, diplopia, impaired mentation, lethargy, abnormal coordination, stupor, hypotension, abdominal pain, agitation, dizziness and depression. The clinical consequences were not severe in most cases, but deaths have been reported after overdoses with multiple medicinal products including topiramate.

Topiramate overdose can result in severe metabolic acidosis (see section 4.4).

#### Treatment

In acute topiramate overdose, if the ingestion is recent, the stomach should be emptied immediately by lavage or by induction of emesis. Treatment should be appropriately supportive and the patient should be well hydrated. Haemodialysis has been shown to be an effective means of removing topiramate from the body. Other measures may also be taken at the physician's discretion.

## 5 PHARMACOLOGICAL PROPERTIES

### 5.1 Pharmacodynamic properties

Pharmacotherapeutic group: antiepileptics, other antiepileptics, ATC code: N03AX11

Topiramate is classified as a sulfamate-substituted monosaccharide. The precise mechanism by which topiramate exerts its antiseizure and migraine prophylaxis effects are unknown. Electrophysiological and biochemical studies on cultured neurons have identified three properties that may contribute to the antiepileptic efficacy of topiramate.

Action potentials elicited repetitively by a sustained depolarization of the neurons were blocked by topiramate in a time-dependent manner, suggestive of a state-dependent sodium

channel blocking action. Topiramate increased the frequency at which  $\gamma$ -aminobutyrate (GABA) activated GABA<sub>A</sub> receptors, and enhanced the ability of GABA to induce a flux of chloride ions into neurons, suggesting that topiramate potentiates the activity of this inhibitory neurotransmitter.

This effect was not blocked by flumazenil, a benzodiazepine antagonist, nor did topiramate increase the duration of the channel open time, differentiating topiramate from barbiturates that modulate GABA<sub>A</sub> receptors.

Because the antiepileptic profile of topiramate differs markedly from that of the benzodiazepines, it may modulate a benzodiazepine-insensitive subtype of GABA<sub>A</sub> receptor. Topiramate antagonized the ability of kainate to activate the kainate/AMPA ( $\alpha$ -amino-3-hydroxy-5-methylisoxazole-4-propionic acid) subtype of excitatory amino acid (glutamate) receptor, but had no apparent effect on the activity of Nmethyl-D-aspartate (NMDA) at the NMDA receptor subtype. These effects of topiramate were concentration-dependent over a range of 1  $\mu$ M to 200  $\mu$ M, with minimum activity observed at 1  $\mu$ M to 10  $\mu$ M.

In addition, topiramate inhibits some isoenzymes of carbonic anhydrase. This pharmacologic effect is much weaker than that of acetazolamide, a known carbonic anhydrase inhibitor, and is not thought to be a major component of topiramate's antiepileptic activity.

In animal studies, topiramate exhibits anticonvulsant activity in rat and mouse maximal electroshock seizure (MES) tests and is effective in rodent models of epilepsy, which include tonic and absence-like seizures in the spontaneous epileptic rat (SER) and tonic and clonic seizures induced in rats by kindling of the amygdala or by global ischemia. Topiramate is only weakly effective in blocking clonic seizures induced by the GABA<sub>A</sub> receptor antagonist, pentylenetetrazole.

Studies in mice receiving concomitant administration of topiramate and carbamazepine or phenobarbital showed synergistic anticonvulsant activity, while combination with phenytoin showed additive anticonvulsant activity. In well controlled add-on trials, no correlation has been demonstrated between trough plasma concentrations of topiramate and its clinical efficacy. No evidence of tolerance has been demonstrated in man.

#### Absence seizures

Two small one arm studies were carried out with children aged 4-11 years old (CAPSS-326 and TOPAMAT-ABS-001). One included 5 children and the other included 12 children before it was terminated early due to lack of therapeutic response. The doses used in these studies were up to approximately 12 mg/kg in study TOPAMAT-ABS-001 and a maximum of the lesser of 9 mg/kg/day or 400 mg/day in study CAPSS-326. These studies do not provide sufficient evidence to reach conclusion regarding efficacy or safety in the paediatric population.

#### Monotherapy Treatment in Patients 6 to 15 Years Old with New or Recent Epilepsy

A one year, open-label study in paediatric patients aged 6 to 15 years including 63 subjects with recent or new onset of epilepsy was conducted to assess the effects of topiramate (28 subjects) versus levetiracetam on growth, development, and bone mineralisation. Continued growth was observed in both treatment groups but the topiramate group showed statistically significant reductions in mean annual change from baseline in body weight and bone mineral density compared to the levetiracetam group. A similar trend was also observed for height and height velocity but were not statistically significant. Growth-related changes were not clinically significant nor treatment limiting. Other confounding factors cannot be excluded.

## 5.2 Pharmacokinetic properties

The pharmacokinetic profile of topiramate compared to other AEDs shows a long plasma half-life, linear pharmacokinetics, predominantly renal clearance, absence of significant protein binding, and lack of clinically relevant active metabolites.

Topiramate is not a potent inducer of drug metabolizing enzymes, can be administered without regard to meals, and routine monitoring of plasma topiramate concentrations is not necessary. In clinical studies, there was no consistent relationship between plasma concentrations and efficacy or adverse events.

### Absorption

Topiramate is rapidly and well absorbed. Following oral administration of 100 mg topiramate to healthy subjects, a mean peak plasma concentration ( $C_{max}$ ) of 1.5  $\mu\text{g/ml}$  was achieved within 2 to 3 hours ( $T_{max}$ ).

Based on the recovery of radioactivity from the urine the mean extent of absorption of a 100 mg oral dose of  $^{14}\text{C}$ -topiramate was at least 81%. There was no clinically significant effect of food on the bioavailability of topiramate.

### Distribution

Generally, 13 to 17% of topiramate is bound to plasma protein. A low capacity binding site for topiramate in/on erythrocytes that is saturable above plasma concentrations of 4  $\mu\text{g/ml}$  has been observed. The volume of distribution varied inversely with the dose. The mean apparent volume of distribution was 0.80 to 0.55 l/kg for a single dose range of 100 to 1200 mg. An effect of gender on the volume of distribution was detected, with values for females circa 50% of those for males. This was attributed to the higher percent body fat in female patients and is of no clinical consequence.

### Biotransformation

Topiramate is not extensively metabolized (~20%) in healthy volunteers. It is metabolized up to 50% in patients receiving concomitant antiepileptic therapy with known inducers of drug metabolizing enzymes. Six metabolites, formed through hydroxylation, hydrolysis and glucuronidation, have been isolated, characterized and identified from plasma, urine and faeces of humans. Each metabolite represents less than 3% of the total radioactivity excreted following administration of  $^{14}\text{C}$ -topiramate. Two metabolites, which retained most of the structure of topiramate, were tested and found to have little or no anticonvulsant activity.

### Elimination

In humans, the major route of elimination of unchanged topiramate and its metabolites is via the kidney (at least 81% of the dose). Approximately 66% of a dose of  $^{14}\text{C}$ -topiramate was excreted unchanged in the urine within four days. Following twice a day dosing with 50 mg and 100 mg of topiramate the mean renal clearance was approximately 18 ml/min and 17 ml/min, respectively. There is evidence of renal tubular reabsorption of topiramate. This is supported by studies in rats where topiramate was co-administered with probenecid, and a significant increase in renal clearance of topiramate was observed. Overall, plasma clearance is approximately 20 to 30 ml/min in humans following oral administration.

### Linearity/non-linearity

Topiramate exhibits low intersubject variability in plasma concentrations and, therefore, has predictable pharmacokinetics. The pharmacokinetics of topiramate are linear with plasma clearance remaining constant and area under the plasma concentration curve increasing in a dose-proportional manner over a 100 to 400 mg single oral dose range in healthy subjects.

Patients with normal renal function may take 4 to 8 days to reach steady-state plasma concentrations. The mean  $C_{max}$  following multiple, twice a day oral doses of 100 mg to healthy subjects was 6.76 µg/ml. Following administration of multiple doses of 50 mg and 100 mg of topiramate twice a day, the mean plasma elimination half-life was approximately 21 hours.

### Use with other AEDs

Concomitant multiple-dose administration of topiramate, 100 to 400 mg twice a day, with phenytoin or carbamazepine shows dose proportional increases in plasma concentrations of topiramate.

### Renal impairment

The plasma and renal clearance of topiramate are decreased in patients with moderate and severe impaired renal function ( $CL_{CR} \leq 70$  ml/min). As a result, higher steady-state topiramate plasma concentrations are expected for a given dose in renal-impaired patients as compared to those with normal renal function. In addition, patients with renal impairment will require a longer time to reach steady-state at each dose. In patients with moderate and severe renal impairment, half of the usual starting and maintenance dose is recommended.

Topiramate is effectively removed from plasma by haemodialysis. A prolonged period of hemodialysis may cause topiramate concentration to fall below levels that are required to maintain an anti-seizure effect. To avoid rapid drops in topiramate plasma concentration during hemodialysis, a supplemental dose of topiramate may be required. The actual adjustment should take into account 1) the duration of dialysis period, 2) the clearance rate of the dialysis system being used, and 3) the effective renal clearance of topiramate in the patient being dialyzed.

### Hepatic impairment

Plasma clearance of topiramate decreased a mean of 26% in patients with moderate to severe hepatic impairment. Therefore, topiramate should be administered with caution in patients with hepatic impairment.

### Elderly population

Plasma clearance of topiramate is unchanged in elderly subjects in the absence of underlying renal disease.

### Paediatric population (pharmacokinetics, up to 12 years of age)

The pharmacokinetics of topiramate in children, as in adults receiving add-on therapy, are linear, with clearance independent of dose and steady-state plasma concentrations increasing in proportion to dose. Children, however, have a higher clearance and a shorter elimination half-life. Consequently, the plasma concentrations of topiramate for the same mg/kg dose may be lower in children compared

to adults. As in adults, hepatic enzyme inducing AEDs decrease the steady-state plasma concentrations.

### 5.3 Preclinical safety data

In nonclinical studies of fertility, despite maternal and paternal toxicity as low as 8 mg/kg/day, no effects on fertility were observed, in male or female rats with doses up to 100 mg/kg/day.

In preclinical studies, topiramate has been shown to have teratogenic effects in the species studied (mice, rats and rabbits). In mice, fetal weights and skeletal ossification were reduced at 500 mg/kg/day in conjunction with maternal toxicity. Overall numbers of fetal malformations in mice were increased for all drug-treated groups (20, 100 and 500 mg/kg/day).

In rats, dosage-related maternal and embryo/fetal toxicity (reduced fetal weights and/or skeletal ossification) were observed down to 20 mg/kg/day with teratogenic effects (limb and digit defects) at 400 mg/kg/day and above. In rabbits, dosage-related maternal toxicity was noted down to 10 mg/kg/day with embryo/fetal toxicity (increased lethality) down to 35 mg/kg/day, and teratogenic effects (rib and vertebral malformations) at 120 mg/kg/day.

The teratogenic effects seen in rats and rabbits were similar to those seen with carbonic anhydrase inhibitors, which have not been associated with malformations in humans. Effects on growth were also indicated by lower weights at birth and during lactation for pups from female rats treated with 20 or 100 mg/kg/day during gestation and lactation. In rats, topiramate crosses the placental barrier.

In juvenile rats, daily oral administration of topiramate at doses up to 300 mg/kg/day during the period of development corresponding to infancy, childhood, and adolescence resulted in toxicities similar to those in adult animals (decreased food consumption with decreased body weight gain, centrolobular hepatocellular hypertrophy). There were no relevant effects on long bone (tibia) growth or bone (femur) mineral density, preweaning and reproductive development, neurological development (including assessments on memory and learning), mating and fertility or hysterotomy parameters.

In a battery of *in vitro* and *in vivo* mutagenicity assays, topiramate did not show genotoxic potential.

## 6 PHARMACEUTICAL PARTICULARS

### 6.1 List of excipients

Citric acid monohydrate (E330)  
Disodium hydrogen phosphate dihydrate (E339)  
Simethicone emulsion (including benzoic acid (E210))  
Sucralose (E955)  
Blackcurrant flavour PHS-146010

Sodium methyl hydroxybenzoate (E219)  
Sodium ethyl hydroxybenzoate (E215)  
Dilute hydrochloric acid (E507)  
Xanthan gum (E415)  
Glycerol (E422)  
Purified water

## 6.2 Incompatibilities

None known.

## 6.3 Shelf life

Unopened: 2 years

After first opening: 1 month

## 6.4 Special precautions for storage

Store in a refrigerator (2°C - 8°C).

## 6.5 Nature and contents of container

Bottle: Amber (Type III glass)

Closure: HDPE, EPE wadded, child resistant closure

Syringe: Polypropylene body, purple HDPE plunger with a capacity of 5ml and dosage graduation at every 0.25ml

Bottle adaptor: Low Density Polyethylene

Pack size: 150ml or 280ml. Not all pack sizes may be marketed.

## 6.6 Special precautions for disposal

Any unused product or waste material should be disposed of in accordance with local requirements.

Shake the bottle before use.

### **Instructions for use of the syringe:**

1. To open the bottle, press the cap down and turn it anti-clockwise (figure 1).
2. Put the syringe adaptor into the bottle neck (figure 2).
3. Take the syringe and put it into the adaptor opening (figure 3).
4. Turn the bottle upside down (figure 4).
5. Fill the syringe with a small amount of solution by pulling the plunger down (figure 4A). Then push the plunger upward in order to remove any possible bubbles (figure 4B). Finally, pull the plunger down to the graduation mark corresponding to the quantity in

millilitres (ml) prescribed by your doctor. The top flat edge of the piston should be in line with the graduation mark you are measuring to (Figure 4C).

6. Turn the bottle the right way up (Figure 5A).
7. Remove the syringe from the adaptor (Figure 5B).
8. Put the end of the syringe into your mouth and push the plunger slowly back in to take the medicine (Figure 6).
9. Wash the syringe with water and let it dry before you use it again.
10. Close the bottle with the plastic screw cap - leave the syringe adaptor in the bottle.

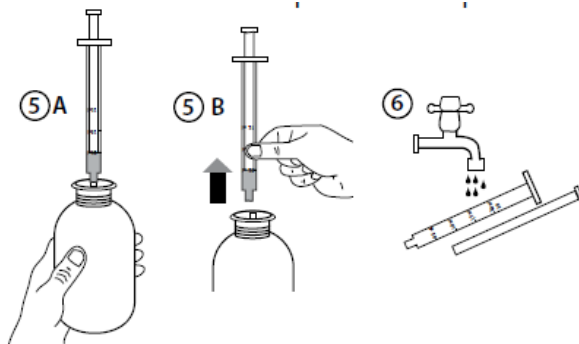
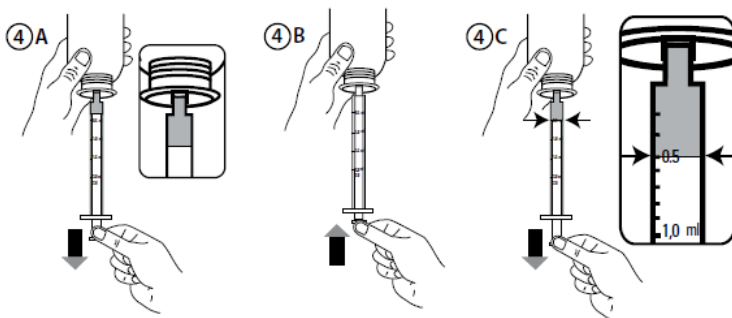
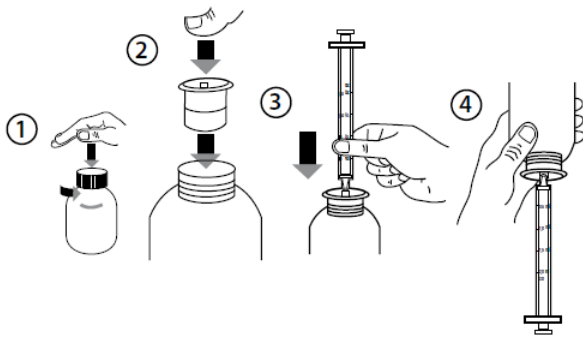

## 7 MARKETING AUTHORISATION HOLDER

Rosemont Pharmaceuticals Ltd  
Rosemont House  
Yorkdale Industrial Park  
Braithwaite Street  
Leeds  
LS11 9XE

UK

**8    MARKETING AUTHORISATION NUMBER(S)**

PL 00427/0246

**9    DATE OF FIRST AUTHORISATION/RENEWAL OF THE  
AUTHORISATION**

06/03/2025

**10   DATE OF REVISION OF THE TEXT**

14/04/2025