

XXXXXX-XX

**PACKAGE LEAFLET:
INFORMATION FOR THE USER****Octaplex 500 IU powder and solvent
for solution for infusion**

Human prothrombin complex

**Octaplex 1000 IU powder and solvent
for solution for infusion**

Human prothrombin complex

**Read all of this leaflet carefully before you
start using this medicine because it contains
important information for you.**

- Keep this leaflet. You may need to read it again.
- If you have any further questions, ask your doctor, pharmacist or nurse.
- This medicine has been prescribed for you only. Do not pass it on to others. It may harm them, even if their signs of illness are the same as yours.
- If you get any side effects, talk to your doctor, pharmacist or nurse. This includes any possible side effects not listed in this leaflet. See section 4.

**What is in this leaflet:**

1. What Octaplex is and what it is used for
2. What you need to know before you use Octaplex
3. How to use Octaplex
4. Possible side effects
5. How to store Octaplex
6. Contents of the pack and other information

1. WHAT OCTAPLEX IS AND WHAT IT IS USED FOR

Octaplex belongs to a group of medicines called clotting factors. It contains the human vitamin K dependent blood coagulation factors II, VII, IX and X.

Octaplex is used to treat and prevent bleeding:

- caused by medicines called vitamin K antagonists (such as warfarin). These medicines block the effect of vitamin K and cause a shortage of the vitamin K dependent clotting factors in your body. Octaplex is used when rapid correction of the shortage is required.
- in people born with a shortage of the vitamin K dependent clotting factors II and X. It is used when purified specific clotting factor product is not available.

**2. WHAT YOU NEED TO KNOW BEFORE YOU USE
OCTAPLEX****Octaplex must not be used:**

- if you are allergic to one of the ingredients of this product (listed in section 6).
- if you are allergic to heparin or if heparin has ever caused a reduction in the level of platelets in your blood.
- if you have IgA deficiency with known antibodies against IgA.

Warnings and precautions

Take the advice of a doctor who specialises in clotting disorders, when receiving Octaplex.

If you have an acquired deficiency of the vitamin K dependent clotting factors (for example caused by treatment with vitamin K antagonist medicines), Octaplex should only be used when rapid correction of the shortage is necessary such as major bleeding or emergency surgery. In other cases, lowering the dose of the vitamin K antagonist medicine and/or administration of vitamin K is usually sufficient.

If you receive a vitamin K antagonist medicine (like warfarin) you may have an increased risk of forming blood clots. In this case, treatment with Octaplex may enhance the risk.

If you have been born with a shortage of any of the vitamin K dependent factors, specific coagulation factor product should be used when available.

If an allergic or anaphylactic- type reaction occurs, your doctor will stop the infusion immediately and give appropriate treatment.

There is a risk of thrombosis or disseminated intravascular coagulation (serious illness, with clots forming all over the body) when you receive Octaplex (particularly if you receive it regularly should be observed closely for signs or symptoms of intravascular coagulation or thrombosis.

This is especially important if you have a history of coronary heart disease, liver disease, if you are going to have an operation, and also if Octaplex is given to very small babies.

No data is available regarding the use of Octaplex in cases of bleeding during birth due to vitamin K deficiency in the newborn.

Viral Safety

When medicines are made from human blood or plasma, certain measures are put in place to prevent infections being passed on to patients. These include careful selection of blood and plasma donors to make sure those at risk of carrying infections are excluded, and the testing of each donation and pools of plasma for signs of virus/infections. Manufacturers of these products also include steps in the processing of the blood or plasma that can inactivate or remove viruses.

XXXXXX-XX



Despite these measures, when medicines prepared from human blood or plasma are administered, the possibility of passing on infection cannot be totally excluded. This also applies to any unknown or emerging virus or other types of infections.

The measures taken are considered effective for enveloped viruses such as human immunodeficiency virus (HIV), hepatitis B virus (HBV) and hepatitis C virus (HCV). The measures taken may be of limited value against non-enveloped viruses such as hepatitis A virus (HAV) and parvovirus B19. Parvovirus B19 infection may be serious for pregnant women (foetal infection) and for individuals whose immune system is depressed or who suffer from a type of anaemia (e.g. sickle cell disease or haemolytic anaemia).

It is strongly recommended that every time you receive a dose of Octaplex, the name and batch number of the product are recorded in order to maintain a link to the batches used.

Appropriate vaccination (hepatitis A and B) is recommended for you if you receive human plasma-derived prothrombin complex products regularly/repeatedly.

Children and adolescents

No data are available regarding the use of Octaplex in children and adolescents.

Other medicines and Octaplex

Octaplex must not be mixed with other medicinal products.

Octaplex stops the effect of vitamin K antagonist medicines (like warfarin), but no interactions with other medicines are known.

Octaplex may affect the results of clotting tests which are sensitive to heparin.

Tell your doctor or pharmacist if you are taking, have recently taken or might take any other medicines.

Pregnancy and breastfeeding

Octaplex should only be used during pregnancy and breastfeeding if clearly needed. Ask your doctor or pharmacist for advice before taking any medicine.

Driving and using machines

It is not known how Octaplex affects the ability to drive and use machines.

**Important information about some of the
ingredients of Octaplex**

Heparin may cause allergic reactions and reduced blood cell counts which may affect the blood

clotting system. Patients with a history of heparin-induced allergic reactions should avoid the use of heparin containing medicines.

This medicine contains 75 – 125 mg (500 IU vial) or 150 – 250 mg (1000 IU vial) sodium (main component of cooking/table salt) per vial. This is equivalent to 3.8 – 6.3% or 7.5 – 12.5% of the recommended maximum daily dietary intake of sodium for an adult.

3. HOW TO USE OCTAPLEX

Treatment with Octaplex should be started under the supervision of a doctor who is specialised in clotting disorders.

First, the powder is dissolved in water, then the solution is **given into a vein (the intravenous route)**.

How much Octaplex you receive, and for how long, depends on:

- how serious your illness is
- where the bleeding is and how severe it is, and
- your general condition.

If you got more Octaplex than you should

In case of overdose, the risk is higher of developing:

- clotting complications (such as heart attack and clots in your veins or lungs)
- disseminated intravascular coagulation (a serious illness where clots form all over the body).

4. POSSIBLE SIDE EFFECTS

Like all medicines, this medicine can cause side effects, although not everybody gets them.

Common (may affect up to 1 in 10 people)

Clots in blood vessels.

Uncommon (may affect up to 1 in 100 people)

Anxiety, increase in blood pressure, asthma-like symptoms, coughing up blood, bleeding from the nose, injection site burning, clots in device.

Rare (may affect up to 1 in 1,000 people)

Allergic type reactions may occur. A temporary increase in liver test results (transaminases) has been rarely observed.

Patients treated with Octaplex for replacement therapy may develop neutralising antibodies (inhibitors) against any of the contained clotting factors. If such inhibitors occur, the replacement therapy will not be very effective.

Very rare (may affect up to 1 in 10,000 people)

Increase in body temperature (fever) has been observed.

There is a risk of blood clotting following the administration of this medicine.

Not known (frequency cannot be estimated from the available data)

Serious allergic reaction and shock, hypersensitivity, tremor, failure of the heart, increase in heart rate, failure of the blood circulation, drop in blood pressure, respiratory failure, difficulty in breathing, nausea, hives, rash, chills.

The heparin in the preparation may cause a sudden fall in the number of platelets in the blood. This is an allergic reaction called "heparin-induced thrombocytopenia type II". In rare cases in patients not previously hypersensitive to heparin, this fall in the number of platelets can occur 6–14 days after the start of treatment. In patients with a previous heparin hypersensitivity, this alteration may develop within a few hours of starting treatment.

The treatment with Octaplex must be stopped immediately in patients showing this allergic reaction. These patients must not receive heparin containing medicinal products in the future.

For information on viral safety see section 2.

Reporting of side effects

If you get any side effects, talk to your doctor, pharmacist or nurse. This includes any possible side effects not listed in this leaflet. You can also report side effects directly via www.mhra.gov.uk/yellowcard. By reporting side effects, you can help provide more information on the safety of this medicine.

5. HOW TO STORE OCTAPLEX

Keep this medicine out of the sight and reach of children.

Do not use this medicine after the expiry date which is stated on the label. The expiry date refers to the last day of that month.

Do not store above 25°C. Do not freeze. Store in the original package in order to protect from light.

The powder should be dissolved only directly before injection. The stability of the solution has been demonstrated for up to 8 hours at +25°C. Nevertheless, to prevent contamination, the solution should be used immediately and on one occasion only.

XXXXXX-XX

**6. CONTENTS OF THE PACK AND OTHER
INFORMATION**

**What Octaplex contains, per vial and
after reconstitution with 20 mL (500 IU)/
40 mL (1000 IU) solvent**

The active substances are:

Name of ingredient	Octaplex Quantity per 500 IU vial	Octaplex Quantity per 1000 IU vial	Octaplex Quantity per mL reconstituted solution
Total protein:	260 – 820 mg	520 – 1640 mg	13 – 41 mg/mL
<i>Active substances</i>			
Human coagulation factor II	280 – 760 IU	560 – 1520 IU	14 – 38 IU/mL
Human coagulation factor VII	180 – 480 IU	360 – 960 IU	9 – 24 IU/mL
Human coagulation factor IX	500 IU	1000 IU	25 IU/mL
Human coagulation factor X	360 – 600 IU	720 – 1200 IU	18 – 30 IU/mL
<i>Further active ingredients</i>			
Protein C	260 – 620 IU	520 – 1240 IU	13 – 31 IU/mL
Protein S	240 – 640 IU	480 – 1280 IU	12 – 32 IU/mL

The specific activity of the product is ≥ 0.6 IU/mg proteins, expressed as factor IX activity.

The other ingredients are:

Heparin, tri-sodium citrate dihydrate, Water for Injections.

What Octaplex looks like and contents of the pack

Octaplex is presented as a powder and solvent for solution for infusion and is a hygroscopic, white or slightly coloured powder or friable mass in a glass vial. The solvent is Water for Injections and is provided in a glass vial. The reconstituted solution is clear or slightly opalescent and may be coloured.

Octaplex is sold in one carton containing:

- 1 vial with powder for solution for infusion
- 1 vial with the solvent, Water for Injections
- 1 Nextaro® transfer device

Marketing Authorization Holder and Manufacturer

Marketing Authorization Holder

Octapharma Limited
Glassworks House
32 Shudehill
Manchester M4 1EZ
United Kingdom

Manufacturers

Octapharma Pharmazeutika
Produktionsges.m.b.H.
Oberlaaer Str. 235
1100 Vienna
Austria

Octapharma Lingolsheim S.A.S.
72 Rue du Maréchal Foch
67380 Lingolsheim
France

This medicinal product is authorised in the Member States of the EEA under the following names:

Austria, Belgium, Bulgaria, Croatia, Cyprus, Denmark, Estonia, Finland, France, Germany, Greece, Hungary, Iceland, Ireland, Latvia, Lithuania, Luxembourg, Malta, The Netherlands, Norway, Poland, Portugal, Republic of Slovenia, Slovak Republic, Spain, United Kingdom: Octaplex

Czech Republic, Sweden: Ocplex

Italy, Romania: Pronativ

This leaflet was last revised in 06/2024.

INFORMATION FOR HEALTHCARE PROFESSIONALS

General information about how to use Octaplex is provided in section 3.

The following information is intended for medical or healthcare professionals only:

Instructions for Treatment

Please read all the instructions and follow them carefully.

During the procedure described below, aseptic technique must be maintained.

The product reconstitutes quickly at room temperature.

The reconstituted solution should be clear or slightly opalescent.

Do not use solutions that are cloudy or have deposits.

Reconstituted products should be inspected visually for particulate matter and discoloration prior to administration.

After reconstitution the solution must be used immediately.

Any unused product or waste material should be disposed of in accordance with local requirements.

Dose

Bleeding and prevention of bleeding during vitamin K antagonist treatment:

The dose will depend on the international normalised ratio (INR) before treatment and body weight. In the following table approximate doses (units/kg body weight of the reconstituted product) are given.

Pre-treatment INR	2 – < 4	4 – 6	6
Dose of Octaplex (units [†] of factor IX) / kg body weight	25	35	50

[†] Units refer to International Units.

Dose is based on body weight up to, but not exceeding 100 kg. For patients weighing more than 100 kg, the maximum single dose (IU of factor IX) should therefore not exceed 2500 IU for an INR of 2 – < 4, 3500 IU for an INR of 4 – 6 and 5000 IU for an INR of > 6.

As these recommendations are empirical and recovery and the duration of effect may vary, monitoring of INR during treatment is mandatory. Bleeding and perioperative prophylaxis in congenital deficiency of the vitamin K dependent coagulation factors II and X when specific coagulation factor product is not available:

The calculated required dosage for treatment is based on the empirical finding that approximately 1 IU of factor II or X per kg body weight raises the plasma factor II or X activity by 0.02 and 0.017 IU/mL, respectively.

• Required dosage for factor X:

Required units = body weight (kg) × desired factor X rise (IU/mL) × 60

where 60 (mL/kg) is the reciprocal of the estimated recovery.

• Required dosage for factor II:

Required units = body weight (kg) × desired factor II rise (IU/mL) × 50

where 50 (mL/kg) is the reciprocal of the estimated recovery.

If the individual recovery is known that value should be used for calculation.

Instructions for reconstitution:

1. If necessary, allow the solvent (Water for Injections) and the powder in the closed vials to reach room temperature. This temperature should be maintained during reconstitution. If a water bath is used for warming, care must be taken to avoid water coming into contact with the rubber stoppers or the caps of the vials. The temperature of the water bath should not exceed 37°C.

2. Remove the flip-off caps from the powder vial and the solvent vial and disinfect the rubber stoppers appropriately.

3. Peel away the lid of the outer package of the Nextaro®. Place the solvent vial on an even surface and hold it firmly. Without removing the outer package, place the blue part of the Nextaro® on top of the solvent vial and press firmly down until it snaps (Fig. 1). Do not twist while attaching. While holding onto the solvent vial, carefully remove the outer package from the Nextaro®, being careful to leave the Nextaro® attached firmly to the solvent vial (Fig. 2).

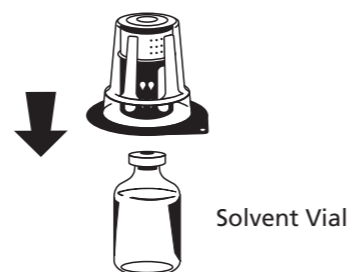

Fig. 1

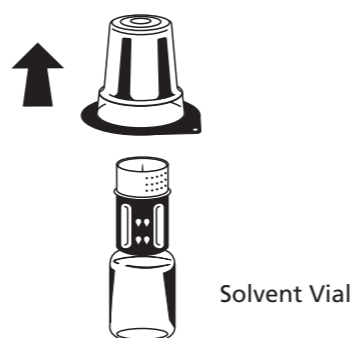

Fig. 2

4. Place the powder vial on an even surface and hold it firmly. Take the solvent vial with the attached Nextaro® and turn it upside down. Place the white part of the Nextaro® connector on top of the powder vial and press firmly down until it snaps (Fig. 3). Do not twist while attaching. The solvent flows automatically into the powder vial.

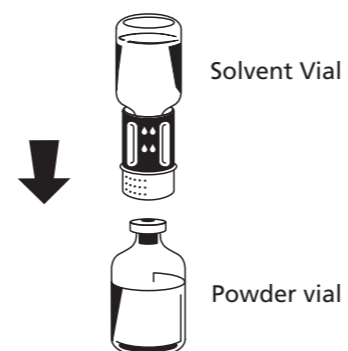

Fig. 3

5. With both vials still attached, gently swirl the powder vial until the product is dissolved.

Octaplex dissolves quickly at room temperature to a colourless to slightly blue solution. Unscrew the Nextaro® into two parts (Fig. 4).

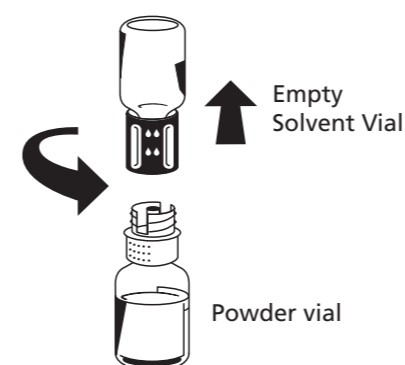

Fig. 4

Dispose the empty solvent vial with the blue part of the Nextaro®.

If the powder fails to dissolve completely or an aggregate is formed, do not use the preparation.

Instructions for infusion:

As a precautionary measure, the patients pulse rate should be measured before and during the infusion. If a marked increase in the pulse rate occurs the infusion speed must be reduced or the administration must be interrupted.

1. Attach a 20 mL (for 500 IU) or 40 mL (for 1000 IU) syringe to the luer lock outlet on the white part of the Nextaro®. Turn the vial upside down and draw the solution into the syringe. Once the solution has been transferred, firmly hold the plunger of the syringe (keeping it facing down) and remove the syringe from the Nextaro®. Dispose the Nextaro® and the empty vial.

2. Disinfect the intended injection site appropriately.

3. Inject the solution intravenously at a rate of 0.12 mL/kg/min (~3 units/kg/min), up to a maximum rate of 8 mL/min (~210 units/min), using an aseptic technique.

No blood must flow into the syringe due to the risk of formation of fibrin clots. The Nextaro® is for single use only.