

## Package leaflet: Information for the user

## EN

### AMGEVITA HCF 20 mg solution for injection in pre-filled syringe AMGEVITA HCF 40 mg solution for injection in pre-filled syringe AMGEVITA HCF 80 mg solution for injection in pre-filled syringe adalimumab

**Read all of this leaflet carefully before you start using this medicine because it contains important information for you.**

- Keep this leaflet. You may need to read it again.
- Your doctor will also give you a **Patient Reminder Card**, which contains important safety information that you need to be aware of before you are given AMGEVITA and during treatment with AMGEVITA. Keep this **Patient Reminder Card** with you.
- If you have any further questions, ask your doctor or pharmacist.
- This medicine has been prescribed for you only. Do not pass it on to others. It may harm them, even if their signs of illness are the same as yours.
- If you get any side effects, talk to your doctor or pharmacist. This includes any possible side effects not listed in this leaflet (see section 4).

#### What is in this leaflet

- What AMGEVITA is and what it is used for
- What you need to know before you use AMGEVITA
- How to use AMGEVITA
- Possible side effects
- How to store AMGEVITA
- Contents of the pack and other information

### 1. What AMGEVITA is and what it is used for

AMGEVITA contains the active substance adalimumab, a medicine that acts on your body's immune (defence) system.

AMGEVITA is intended for the treatment of the inflammatory diseases described below:

- Rheumatoid arthritis
- Polyarticular juvenile idiopathic arthritis
- Enthesitis-related arthritis
- Ankylosing spondylitis
- Axial spondyloarthritis without radiographic evidence of ankylosing spondylitis
- Psoriatic arthritis
- Plaque psoriasis
- Hidradenitis suppurativa
- Crohn's disease
- Ulcerative colitis
- Non-infectious uveitis

The active ingredient in AMGEVITA, adalimumab, is a human monoclonal antibody. Monoclonal antibodies are proteins that attach to a specific target.

The target of adalimumab is a protein called tumour necrosis factor (TNF), which is involved in the immune (defence) system and is present at increased levels in the inflammatory diseases listed above. By attaching to TNF, AMGEVITA decreases the process of inflammation in these diseases.

#### Rheumatoid arthritis

Rheumatoid arthritis is an inflammatory disease of the joints.

AMGEVITA is used to treat rheumatoid arthritis in adults. If you have moderate to severe active rheumatoid arthritis, you may first be given other disease-modifying medicines, such as methotrexate. If you do not respond well enough to these medicines, you will be given AMGEVITA to treat your rheumatoid arthritis.

AMGEVITA can also be used to treat severe, active and progressive rheumatoid arthritis without previous methotrexate treatment.

AMGEVITA slows down the damage to the cartilage and bone of the joints caused by the disease and to improve physical function.

Usually, AMGEVITA is used with methotrexate. If your doctor determines that methotrexate is inappropriate, AMGEVITA can be given alone.

#### Polyarticular juvenile idiopathic arthritis and enthesitis-related arthritis

Polyarticular juvenile idiopathic arthritis and enthesitis-related arthritis are inflammatory diseases of the joints that usually first appear in childhood.

AMGEVITA is used to treat polyarticular juvenile idiopathic arthritis in patients from 2 years and enthesitis-related arthritis in patients from 6 years. You may first be given other disease-modifying medicines, such as methotrexate. If you do not respond well enough to these medicines, you will be given AMGEVITA to treat your polyarticular juvenile idiopathic arthritis or enthesitis-related arthritis.

#### Ankylosing spondylitis and axial spondyloarthritis without radiographic evidence of ankylosing spondylitis

Ankylosing spondylitis and axial spondyloarthritis without radiographic evidence of ankylosing spondylitis, are inflammatory diseases of the spine.

AMGEVITA is used to treat ankylosing spondylitis and axial spondyloarthritis without radiographic evidence of ankylosing spondylitis in adults. If you have ankylosing spondylitis or axial spondyloarthritis without radiographic evidence of ankylosing spondylitis, you will first be given other medicines. If you do not respond well enough to these medicines, you will be given AMGEVITA to reduce the signs and symptoms of your disease.

#### Psoriatic arthritis

Psoriatic arthritis is an inflammation of the joints associated with psoriasis.

AMGEVITA is used to treat psoriatic arthritis in adults. AMGEVITA slows down the damage to the cartilage and bone of the joints caused by the disease and to improve physical function.

#### Plaque psoriasis in adults and children

Plaque psoriasis is a skin condition that causes red, flaky, crusty patches of skin covered with silvery scales. Plaque psoriasis can also affect the nails, causing them to crumble, become thickened and fit away from the nail bed which can be painful. Psoriasis is believed to be caused by a problem with the body's immune system that leads to an increased production of skin cells.

AMGEVITA is used to treat moderate to severe plaque psoriasis in adults. AMGEVITA is also used to treat severe plaque psoriasis in children and adolescents aged 4 to 17 years for whom topical therapy and phototherapies have either not worked very well or are not suitable.

#### Hidradenitis suppurativa in adults and adolescents

Hidradenitis suppurativa (sometimes called acne inversa) is a chronic and often painful inflammatory skin disease. Symptoms may include tender nodules (lumps) and abscesses (boils) that may leak pus. It most commonly affects specific areas of the skin, such as under the breasts, the armpits, inner thighs, groin and buttocks. Scarring may also occur in affected areas.

AMGEVITA is used to treat hidradenitis suppurativa in adults and adolescents from 12 years of age. AMGEVITA can reduce the number of nodules and abscesses you have, and the pain that is often associated with the disease. You may first be given other medicines. If you do not respond well enough to these medicines, you will be given AMGEVITA.

#### Crohn's disease in adults and children

Crohn's disease is an inflammatory disease of the digestive tract.

AMGEVITA is used to treat Crohn's disease in adults and children aged 6 to 17 years. If you have Crohn's disease you will first be given other medicines. If you do not respond well enough to these medicines, you will be given AMGEVITA to reduce the signs and symptoms of your Crohn's disease.

#### Ulcerative colitis in adults and children

Ulcerative colitis is an inflammatory disease of the large intestine.

AMGEVITA is used to treat moderate to severe ulcerative colitis in adults and children aged 6 to 17 years. If you have ulcerative colitis you may first be given other medicines. If you do not respond well enough to these medicines, you will be given AMGEVITA to reduce the signs and symptoms of your disease.

#### Non-infectious uveitis in adults and children

Non-infectious uveitis is an inflammatory disease affecting certain parts of the eye.

AMGEVITA is used to treat

- Adults with non-infectious uveitis with inflammation affecting the back of the eye.
- Children from 2 years of age with chronic non-infectious uveitis with inflammation affecting the front of the eye.

This inflammation may lead to a decrease of vision and/or the presence of floaters in the eye (black dots or wispy lines that move across the field of vision). AMGEVITA works by reducing this inflammation.

### 2. What you need to know before you use AMGEVITA

**Do not use AMGEVITA:**

- If you are allergic to adalimumab or any of the other ingredients of this medicine (listed in section 6).
- If you have a severe infection, including active tuberculosis, sepsis (blood infection) or other opportunistic infections (unusual infections associated with a weakened immune system) (see "Warnings and precautions"). It is important that you tell your doctor if you have symptoms of infections, e.g. fever, wounds, feeling tired, dental problems.
- If you have moderate or severe heart failure. It is important to tell your doctor if you have had or have a serious heart condition (see "Warnings and precautions").

#### Warnings and precautions

Talk to your doctor or pharmacist before using AMGEVITA:

Allergic reactions

- If you experience allergic reactions with symptoms such as chest tightness, wheezing, dizziness, swelling or rash do **not** inject more AMGEVITA and contact your doctor immediately since, in rare cases, these reactions can be life threatening.

#### Infections

- If you have an infection, including long-term or localised infection (for example, leg ulcer) consult your doctor before starting AMGEVITA. If you are unsure, contact your doctor.
- You might get infections more easily while you are receiving AMGEVITA treatment. This risk may increase if your lung function is impaired. These infections may be serious and include tuberculosis, infections caused by viruses, fungi, parasites or bacteria, or other opportunistic infections and sepsis that may, in rare cases, be life-threatening. It is important to tell your doctor if you get symptoms such as fever, wounds, feeling tired or dental problems. Your doctor may recommend temporary discontinuation of AMGEVITA.

#### Tuberculosis

- As cases of tuberculosis have been reported in patients treated with adalimumab, your doctor will check you for signs and symptoms of tuberculosis before starting AMGEVITA. This will include a thorough medical evaluation including your medical history and appropriate screening tests (for example chest x-ray and a tuberculin test). The conduct and results of these tests should be recorded on your **Patient Reminder Card**. It is very important that you tell your doctor if you have ever had tuberculosis, or if you have been in close contact with someone who has had tuberculosis.
- Tuberculosis can develop during therapy even if you have received preventative treatment for tuberculosis.
- If symptoms of tuberculosis (persistent cough, weight loss, listlessness, mild fever), or any other infection appear during or after therapy, tell your doctor immediately.

#### Travel / recurrent infection

- Advise your doctor if you reside or travel in regions where fungal infections such as histoplasmosis, coccidioidomycosis or blastomycosis are endemic.
- Advise your doctor if you have a history of recurrent infections or other conditions that increase the risk of infections.

#### Hepatitis B virus

- Advise your doctor if you are a carrier of the hepatitis B virus (HBV), if you have active HBV or if you think you might be at risk of contracting HBV. Your doctor should test you for HBV. AMGEVITA can cause reactivation of HBV in people who carry this virus. In some rare cases, especially if you are taking other medicines that suppress the immune system, reactivation of HBV can be life-threatening.

#### Age over 65 years

- If you are over 65 years you may be more susceptible to infections while taking AMGEVITA. You and your doctor should pay special attention to signs of infection while you are being treated with AMGEVITA. It is important to tell your doctor if you get symptoms of infections, such as fever, wounds, feeling tired or dental problems.

#### Surgery or dental procedures

- If you are about to undergo surgery or dental procedures please inform your doctor that you are taking AMGEVITA. Your doctor may recommend temporary discontinuation of AMGEVITA.

#### Demyelinating disease

- If you have or develop demyelinating disease such as multiple sclerosis, your doctor will decide if you should receive or continue to receive AMGEVITA. Tell your doctor immediately if you experience symptoms like changes in your vision, weakness in your arms or legs or numbness or tingling in any part of your body.

#### Vaccines

- Certain vaccines contain living but weakened forms of disease-causing bacteria or viruses that may cause infections and should not be given while receiving AMGEVITA. Please check with your doctor before you receive any vaccines. It is recommended that children, if possible, be brought up to date with all immunisations in agreement with current immunisation guidelines prior to initiating AMGEVITA therapy.

- If you received AMGEVITA while you were pregnant, your baby may be at higher risk for getting such an infection for up to approximately five months after the last dose you received during pregnancy. It is important that you tell your baby's doctors and other health care professionals about your AMGEVITA use during your pregnancy so they can decide when your baby should receive any vaccine.

#### Heart failure

- If you have mild heart failure and you are being treated with AMGEVITA, your heart failure status must be closely monitored by your doctor. It is important to tell your doctor if you have had or have a serious heart condition. If you develop new or worsening symptoms of heart failure (e.g. shortness of breath, or swelling of your feet), you must contact your doctor immediately. Your doctor will decide if you should receive AMGEVITA.

#### Fever, bruising, bleeding or looking pale

- In some patients the body may fail to produce enough of the blood cells that help your body fight infections or help you to stop bleeding. If you develop a fever that does not go away, bruise or bleed very easily or look very pale, call your doctor right away. Your doctor may decide to stop treatment.

#### Cancer

- There have been very rare cases of certain kinds of cancer in children and adult patients taking adalimumab or other TNF blockers. People with more serious rheumatoid arthritis that have had the disease for a long time may have a higher than average risk of getting lymphoma (a cancer that affects the lymph system), and leukaemia (a cancer that affects the blood and bone marrow).
- If you take AMGEVITA the risk of getting lymphoma, leukaemia, or other cancers may increase. On rare occasions, a specific and severe type of lymphoma has been observed in patients taking adalimumab. Some of those patients were also treated with azathioprine or 6-mercaptopurine. Tell your doctor if you are taking azathioprine or 6-mercaptopurine with AMGEVITA.
- In addition, cases of non-melanoma skin cancer have been observed in patients taking adalimumab. If new skin lesions appear during or after therapy or if existing lesions change appearance, tell your doctor.
- There have been cases of cancers, other than lymphoma in patients with a specific type of lung disease called Chronic Obstructive Pulmonary Disease (COPD) treated with another TNF blocker. If you have COPD, or are a heavy smoker, you should discuss with your doctor whether treatment with a TNF blocker is appropriate for you.

#### Autoimmune diseases

- On rare occasions, treatment with AMGEVITA could result in lupus-like syndrome. Contact your doctor if symptoms such as persistent unexplained rash, fever, joint pain or tiredness occur.

In order to improve the traceability of this medicine, your doctor or pharmacist should record the name and the lot number of the product you have been given in your patient file. You may also wish to make a note of these details in case you are asked for this information in the future.

#### Children and adolescents

- Vaccinations: if possible children should be up to date with all vaccinations before using AMGEVITA.

- Do not give AMGEVITA to children with polyarticular juvenile idiopathic arthritis below the age of 2 years.

- Do not give AMGEVITA to children with plaque psoriasis below the age of 4 years.

- Do not give AMGEVITA to children with Crohn's disease or ulcerative colitis below the age of 6 years.

#### Other medicines and AMGEVITA

Tell your doctor or pharmacist if you are taking, have recently taken or might take any other medicines.

AMGEVITA can be taken together with methotrexate or certain disease-modifying anti-rheumatic agents (sulfasalazine, hydroxychloroquine, leflunomide and injectable gold preparations), steroids or pain medications including non-steroidal anti-inflammatory drugs (NSAIDs).

You should not take AMGEVITA with medicines containing the active substances, anakinra or abatacept due to increased risk of serious infection. If you have questions, please ask your doctor.

#### Pregnancy and breast-feeding

- You should consider the use of adequate contraception to prevent pregnancy and continue its use for at least 5 months after the last AMGEVITA treatment.
- If you are pregnant, think you may be pregnant or are planning to have a baby, ask your doctor for advice about taking this medicine.
- AMGEVITA should only be used during a pregnancy if needed.
- According to a pregnancy study, there was no higher risk of birth defects when the mother had received AMGEVITA during pregnancy compared with mothers with the same disease who did not receive AMGEVITA.
- AMGEVITA can be used during breast-feeding.
- If you receive AMGEVITA during your pregnancy, your baby may have a higher risk for getting an infection.
- It is important that you tell your baby's doctors and other health care professionals about your AMGEVITA use during your pregnancy before the baby receives any vaccine. For more information on vaccines see the "Warnings and precautions" section.

#### Driving and using machines

AMGEVITA may have a minor influence on your ability to drive, cycle or use machines. Room spinning sensation (vertigo) and vision disturbances may occur after taking AMGEVITA.

#### AMGEVITA contains sodium

This medicine contains less than 1 mmol of sodium (23 mg) per 0.8 mL dose, that is to say essentially 'sodium-free'.

### 3. How to use AMGEVITA

Always use this medicine exactly as your doctor or pharmacist has told you. Check with your doctor or pharmacist if you are not sure.

**Adults with rheumatoid arthritis, psoriatic arthritis, ankylosing spondylitis or axial spondyloarthritis without radiographic evidence of ankylosing spondylitis**

AMGEVITA is injected under the skin (subcutaneous use). The usual dose for adults with rheumatoid arthritis, ankylosing spondylitis, axial spondyloarthritis without radiographic evidence of ankylosing spondylitis, and for patients with psoriatic arthritis is 40 mg every other week as a single dose.

In rheumatoid arthritis, methotrexate is continued while using AMGEVITA. If your doctor determines that methotrexate is inappropriate, AMGEVITA can be given alone.

If you have rheumatoid arthritis and you do not receive methotrexate with your AMGEVITA therapy, your doctor may decide to give 40 mg every week or 80 mg every other week.

#### Children, adolescents and adults with polyarticular juvenile idiopathic arthritis

*Children and adolescents from 2 years of age weighing 10 kg to less than 30 kg*

The recommended dose of AMGEVITA is 20 mg every other week.

*Children, adolescents and adults from 2 years of age weighing 30 kg or more*

The recommended dose of AMGEVITA is 40 mg every other week.

#### Children, adolescents and adults with enthesitis-related arthritis

*Children and adolescents from 6 years of age weighing 15 kg to less than 30 kg*

The recommended dose of AMGEVITA is 20 mg every other week.

*Children, adolescents and adults from 6 years of age weighing 30 kg or more*

The recommended dose of AMGEVITA is 40 mg every other week.

#### Adults with plaque psoriasis

The usual dose for adults with plaque psoriasis is an initial dose of 80 mg, followed by 40 mg given every other week starting one week after the initial dose. You should continue to inject AMGEVITA for as long as your doctor has told you. Depending on your response, your doctor may increase the dose to 40 mg every week or 80 mg every other week.

#### Children and adolescents with plaque psoriasis

*Children and adolescents from 4 to 17 years of age weighing 15 kg to less than 30 kg*

The recommended dose of AMGEVITA is an initial dose of 20 mg, followed by 20 mg one week later. Thereafter, the usual dose is 20 mg every other week.

*Children and adolescents from 4 to 17 years of age weighing 30 kg or more*

The recommended dose of AMGEVITA is an initial dose of 40 mg, followed by 40 mg one week later. Thereafter, the usual dose is 40 mg every other week.

#### Adults with hidradenitis suppurativa

The usual dose regimen for hidradenitis suppurativa is an initial dose of 160 mg (two 80 mg injections in one day or one 80 mg injection per day for two consecutive days), followed by an 80 mg dose two weeks later. After two further weeks, continue with a dose of 40 mg every week or 80 mg every other week, as prescribed by your doctor. It is recommended that you use an antiseptic wash daily on the affected areas.

#### Adolescents with hidradenitis suppurativa from 12 to 17 years of age weighing 30 kg or more

The recommended dose of AMGEVITA is an initial dose of 80 mg, followed by 40 mg every other week starting one week later. If you have an inadequate response to AMGEVITA 40 mg every other week, your doctor may increase the dose to 40 mg every week or 80 mg every other week.

It is recommended that you use an antiseptic wash daily on the affected areas.

#### Adults with Crohn's disease

The usual dose regimen for Crohn's disease is 80 mg initially followed by 40 mg every other week two weeks later. If a faster response is required, your doctor may prescribe an initial dose of 160 mg (two 80 mg injections in one day or one 80 mg injection per day for two consecutive days), followed by 80 mg two weeks later, and thereafter as 40 mg every other week. Depending on your response, your doctor may increase the dose to 40 mg every week or 80 mg every other week.

#### Children and adolescents with Crohn's disease

*Children and adolescents from 6 to 17 years of age weighing less than 40 kg*

The usual dose regimen is 40 mg initially followed by 20 mg two weeks later. If a faster response is required, your doctor may prescribe an initial dose of 80 mg followed by 40 mg two weeks later.

Thereafter, the usual dose is 20 mg every other week. Depending on your response, your doctor may increase the dose frequency to 20 mg every week.

*Children and adolescents from 6 to 17 years of age weighing 40 kg or more,*

The usual dose regimen is 80 mg initially followed by 40 mg two weeks later. If a faster response is required, your doctor may prescribe an initial dose of 160 mg (two 80 mg injections in one day or one 80 mg injection per day for two consecutive days) followed by 80 mg two weeks later.

Thereafter, the usual dose is 40 mg every other week. Depending on your response, your doctor may increase the dose to 40 mg every week or 80 mg every other week.

#### Adults with ulcerative colitis

The usual AMGEVITA dose for adults with ulcerative colitis is 160 mg initially (two 80 mg injections in one day or one 80 mg injection per day for two consecutive days) followed by 80 mg two weeks later, then 40 mg every other week. Depending on your response, your doctor may increase the dose to 40 mg every week or 80 mg every other week.

#### Children and adolescents with ulcerative colitis

*Children and adolescents from 6 years of age weighing less than 40 kg*

The usual AMGEVITA dose is 80 mg initially followed by 40 mg (as one 40 mg injection) two weeks later. Thereafter, the usual dose is 40 mg every other week.

Patients who turn 18 years of age while on 40 mg every other week, should continue their prescribed dose.

*Children and adolescents from 6 years of age weighing 40 kg or more*

The usual AMGEVITA dose is 160 mg (two 80 mg injections in one day or one 80 mg injection per day for two consecutive days) initially, followed by 80 mg two weeks later. Thereafter the usual dose is 80 mg every other week.

Patients who turn 18 years of age while on 80 mg every other week, should continue their prescribed dose.

#### Adults with non-infectious uveitis

The usual dose for adults with non-infectious uveitis is an initial dose of 80 mg, followed by 40 mg given every other week starting one week after the initial dose. You should continue to inject AMGEVITA for as long as your doctor has told you.

In non-infectious uveitis, corticosteroids or other medicines that influence the immune system may be continued while using AMGEVITA. AMGEVITA can also be given alone.

#### Children and adolescents with chronic non-infectious uveitis from 2 years of age

*Children and adolescents from 2 years of age weighing less than 30 kg*

The usual dose of AMGEVITA is 20 mg every other week with methotrexate.

Your doctor may also prescribe an initial dose of 40 mg which may be administered one week prior to the start of the usual dose.

#### Children and adolescents from 2 years of age weighing 30 kg or more

The usual dose of AMGEVITA is 40 mg every other week with methotrexate.

Your doctor may also prescribe an initial dose of 80 mg which may be administered one week prior to the start of the usual dose.

#### Method and route of administration

AMGEVITA is administered by injection under the skin (subcutaneous injection).

Detailed instructions on how to inject AMGEVITA are provided in "Instructions for use" section.

#### If you use more AMGEVITA than you should

If you accidentally inject AMGEVITA more frequently than told to by your doctor or pharmacist, call your doctor or pharmacist and tell him/her that you have taken more. Always take the outer carton of this medicine with you, even if it is empty.

#### If you forget to use AMGEVITA

If you forget to give yourself an injection, you should inject the next dose of AMGEVITA as soon as you remember. Then take your next dose as you would have on your originally scheduled day, had you not forgotten a dose.

#### If you stop using AMGEVITA

The decision to stop using AMGEVITA should be discussed with your doctor. Your symptoms may return upon discontinuation.

If you have any further questions on the use of this medicine, ask your doctor or pharmacist.

### 4. Possible side effects

Like all medicines, this medicine can cause side effects, although not everybody gets them. Most side effects are mild to moderate. However, some may be serious and require treatment. Side effects may occur at least up to 4 months after the last AMGEVITA injection.

Tell your doctor immediately if you notice any of the following signs of allergic reaction or heart failure:

- severe rash, hives or other signs of allergic reaction;
- swollen face, hands, feet;
- trouble breathing, swallowing;
- shortness of breath with exertion or upon lying down or swelling of the feet.

Tell your doctor as soon as possible if you notice any of the following:

- signs of infection such as fever, feeling sick, wounds, dental problems, burning on urination;
- feeling weak or tired;
- coughing;
- tingling;
- numbness;
- double vision;
- arm or leg weakness;
- signs of skin cancer such as a bump or open sore that doesn't heal;
- signs and symptoms suggestive of blood disorders such as persistent fever, bruising, bleeding, paleness.

## 6. Contents of the pack and other information

### What AMGEVITA contains

- The active substance is adalimumab. Each pre-filled syringe contains 20 mg of adalimumab in 0.2 mL of solution, 40 mg of adalimumab in 0.4 mL of solution or 80 mg of adalimumab in 0.8 mL of solution.
- The other ingredients are L-lactic acid, sucrose, polysorbate 80, sodium hydroxide and water for injections.

### What AMGEVITA looks like and contents of the pack

AMGEVITA is a clear and colourless to slightly yellow solution.

Each pack contains 1 single-use 20 mg pre-filled syringe (with yellow plunger rod).

Each pack contains 1, 2 or 6 single-use 40 mg pre-filled syringes (with blue plunger rod).

Each pack contains 1, 2 or 3 single-use 80 mg pre-filled syringes (with orange plunger rod).

### Marketing Authorisation Holder

Amgen Limited  
216 Cambridge Science Park  
Milton Road  
Cambridge  
CB4 0WA  
United Kingdom

For any information about this medicine, please contact the local representative of the Marketing Authorisation Holder:

Amgen Limited  
Tel: +44 (0)1223 420305

This leaflet was last revised in June 2024.

## INSTRUCTIONS FOR USE

### Getting to know your pre-filled syringe

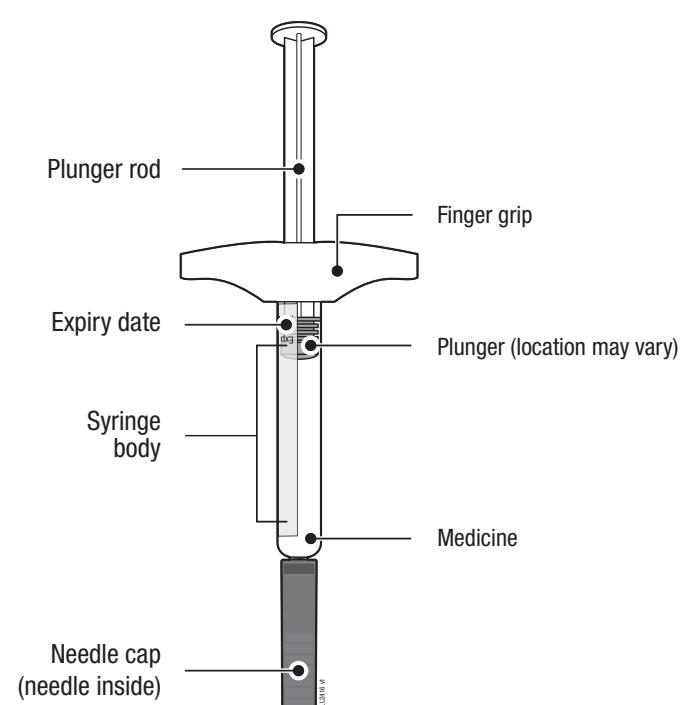

## 1

### Important information you need to know before injecting AMGEVITA

#### Dosing:

- AMGEVITA comes in three different doses: 20 mg/0.2 mL, 40 mg/0.4 mL, 80 mg/0.8 mL. Check your prescription to make sure you have the correct dose.
- The colour and look of the pre-filled syringe will be different for each dose. The amount of medicine in the pre-filled syringe will also be different for each dose.
- For example, it's okay for the 20 mg/0.2 mL dose to have a small amount of medicine and the 80 mg/0.8 mL to have a large amount of medicine. Check the illustrations below to see what your dose looks like in the pre-filled syringe.

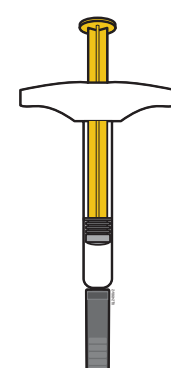

20 mg/0.2 mL

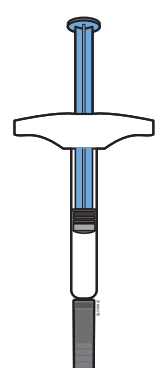

40 mg/0.4 mL

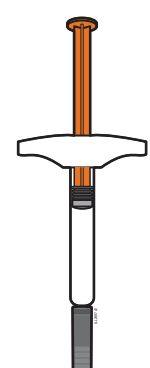

80 mg/0.8 mL

#### Using your AMGEVITA pre-filled syringe:

- It is important that you do not try to give yourself the injection until you have fully read and understood these instructions for use and unless you have received training from your doctor or healthcare provider.
- Do not** use the pre-filled syringe if the carton is damaged or seal is broken.
- Do not** use the pre-filled syringe after the expiry date on the label.
- Do not** shake the pre-filled syringe.
- Do not** remove the needle cap from the pre-filled syringe until you are ready to inject.
- Do not** use the pre-filled syringe if it has been frozen.
- Do not** use the pre-filled syringe if it has been dropped on a hard surface. Part of the pre-filled syringe may be broken even if you cannot see the break. Use a new pre-filled syringe and call your doctor or healthcare provider.
- The pre-filled syringe is not made with natural rubber latex.

**Important:** Keep the pre-filled syringe and sharps disposal container out of the sight and reach of children.

## 2

### Preparing to inject AMGEVITA

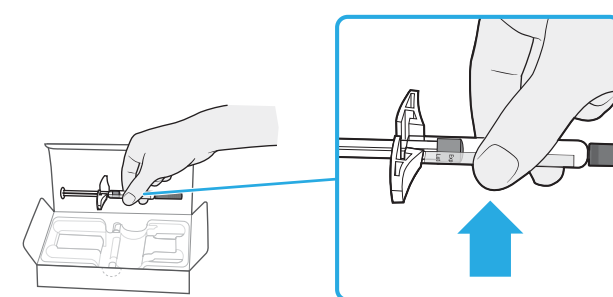

#### 2a Grasp pre-filled syringe by the body and remove from the carton.

- Do not** grab the finger grip, plunger rod, or the needle cap.
- Remove the number of pre-filled syringes you need for your injection.
- Put any unused pre-filled syringes back into the refrigerator.

## 3

### Getting ready for your injection

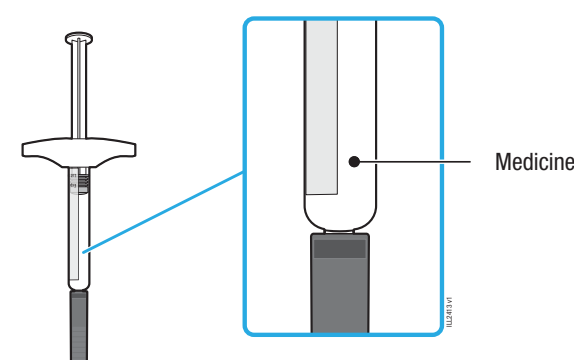

#### 3a Inspect the medicine.

- It should be clear and colourless to slightly yellow.
- It is okay to see air bubbles in the pre-filled syringe.
- Do not** use if the medicine is cloudy, discoloured, or contains flakes, or particles

**Important:** If the medicine is cloudy, discoloured, or contains flakes or particles, call your doctor or healthcare provider.

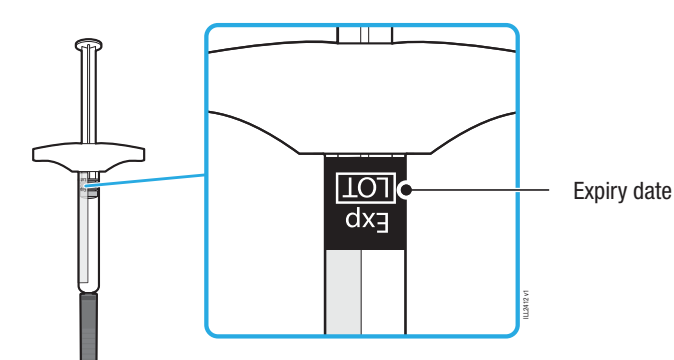

#### 3b Check the expiry date (EXP) and inspect the pre-filled syringe for damage.

- Do not** use if the expiry date has passed.
- Do not** use the pre-filled syringe if:
  - The needle cap is missing or not securely attached.
  - It has cracks or broken parts.
  - It has been dropped on a hard surface.

**Important:** If the pre-filled syringe is medicine is damaged or expired, call your doctor or healthcare provider.

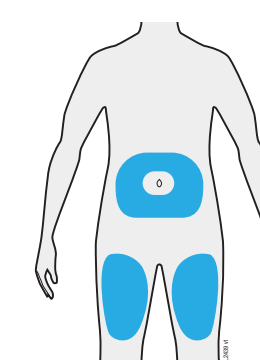

#### 3c Inject in one of these locations.

- Inject in your thigh or belly (except 5 cm around your belly button).
- Choose a different site for each injection.
- Wash your hands thoroughly with soap and water.
- Clean injection site with an alcohol wipe.
- Let your skin dry on its own.
- Do not** touch this area again before injecting.

**Important:** Avoid areas with scars, stretch marks, or where skin is tender, bruised, red or hard.

## 4

### Injecting AMGEVITA

**Important:** Only remove the needle cap when you can inject right away (within 5 minutes) because the medicine can dry out.

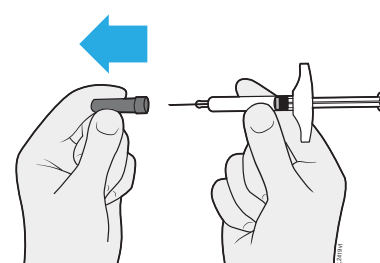

#### 4a Pull the needle cap straight off while holding the pre-filled syringe barrel.

- Do not** twist or bend the needle cap.
- Never** put the needle cap back on. It may damage the needle.
- Do not** let anything touch the needle once the needle cap is removed.
- Do not** place the uncapped pre-filled syringe on any surface once the needle cap is removed.
- Do not** try to push air bubbles out of the pre-filled syringe. It is okay to see air bubbles.
- A drop of medicine is normal.

### PINCH

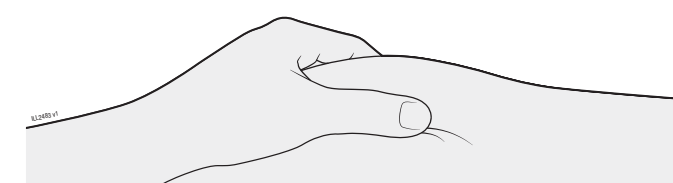

#### 4b Pinch the skin around the injection site before the injection.

- Pinch the skin between thumb and index finger to create a bump for the injection.
- If possible, the bump should be about 5 cm wide.

### INSERT

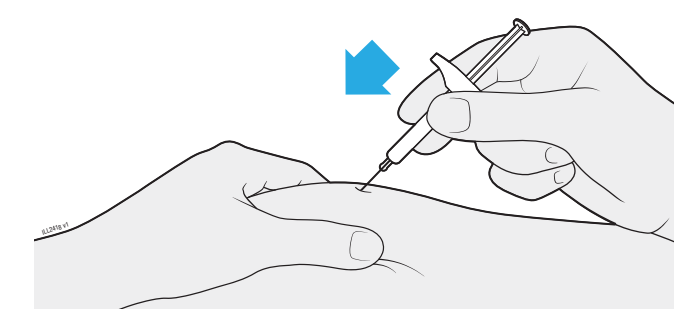

#### 4c Insert the needle into the pinched skin.

- Insert the needle into the pinched skin either straight in or at a 45 degree angle.
- Do not** place your finger on the plunger rod while inserting the needle, as this may result in loss of medicine.

### INJECT

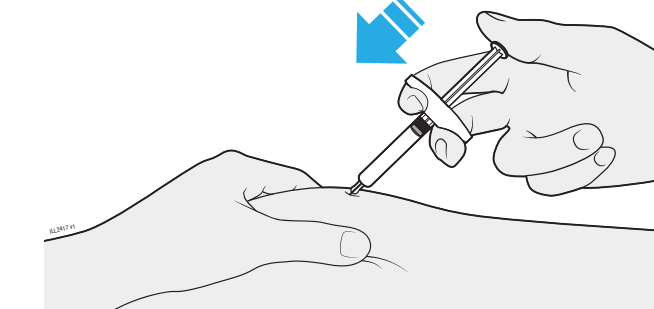

#### 4d Slowly press the plunger rod down to the bottom of the pre-filled syringe to inject the medicine.

- Do not** pull back on the plunger at any time.
- Do not** remove the needle until all the medicine is delivered.

**Important:** Continue to pinch the skin until injection is complete

## 5

### Disposing and finishing AMGEVITA

**Important:** Never put the needle cap back on.

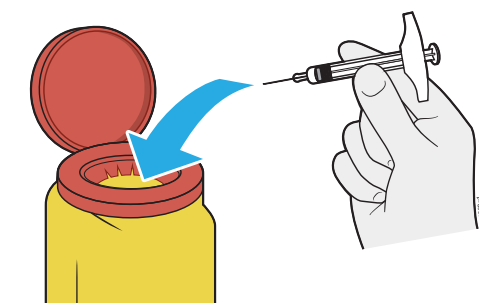

#### 5a Discard the used pre-filled syringe and needle cap in the sharps disposal container.

- Do not** reuse the pre-filled syringe.
  - Do not** use any medicine that is left in the used pre-filled syringe.
  - Put the used AMGEVITA syringe in a sharps disposal container immediately after use. **Do not** throw away (dispose of) the syringe in your household waste.
  - Talk with your doctor or pharmacist about proper disposal. There may be local guidelines for disposal.
  - Do not** recycle the syringe or sharps disposal container or throw them into the household waste.
- Important:** Always keep the sharps disposal container out of the sight and reach of children.

**Do not** recycle the pre-filled syringe or throw it into the household waste.

#### 5b Check injection site.

- Do not** rub the injection site.
- If there is blood, press a cotton ball or gauze pad on your injection site. Apply a plaster if necessary.